

TM 9-4910-663-12

TECHNICAL MANUAL

**OPERATOR'S AND ORGANIZATIONAL MAINTENANCE MANUAL
TEST STAND, AUTOMOTIVE GENERATOR, ALTERNATOR,
STARTER AND ASSOCIATED EQUIPMENT
MODEL GASR-500, PART NUMBER 7458-2
(NSN 4910-01-041-8161)**

HEADQUARTERS, DEPARTMENT OF THE ARMY

10 JUNE 1981

CHANGE
NO. 1

HEADQUARTERS
DEPARTMENT OF THE ARMY
WASHINGTON, DC, 16 October 1987

Technical Manual
Operator's and Organizational Maintenance Manual

TEST STAND
AUTOMOTIVE GENERATOR,
ALTERNATOR, STARTER, AND
ASSOCIATED EQUIPMENT,
MODEL GASR-500

| PART NUMBER | NSN |
|-------------|------------------|
| 7458-2 | 4910-01-041-8161 |
| 7458-4 | 4910-00-767-0218 |

TM 9-4910-663-12, 10 June 1981, is changed as follows:

1. Remove old pages and insert new pages as indicated below.
2. New or changed material is indicated by a vertical bar in the margin of the page.
3. Added or revised illustrations are indicated by a pointing hand.

Remove Pages

i and ii
none
1-1 and 1-2
none
1-3 through 1-6
2-7 and 2-8
2-17 through 2-20
2-23 through 2-28
2-31 and 2-32
none
2-41 and 2-42
2-55 through 2-72
3-1 and 3-2
none
3-3 through 3-6
4-1 and 4-2
none
4-3 through 4-9/(4-10 blank)
D-3 and D-4
Front Cover and Warning Page

Insert Pages

i and ii
ii.1/(ii.2 blank)
1-1 and 1-2
1-2.1/(1-2.2 blank)
1-3 through 1-6
2-7 and 2-8
2-17 through 2-20
2-23 through 2-28
2-31 and 2-32
2-32.1 and 2-32.2
2-41 and 2-42
2-55 through 2-72
3-1 and 3-2
3-2.1 and 3-2.2
3-3 through 3-6
4-1 and 4-2
4-2.1/(4-2.2 blank)
4-3 through 4-9/(4-10 blank)
D-3 and D-4
Front Cover and Warning Page

4. File this change sheet in back of the publication for reference purposes.

By Order of the Secretary of the Army:

CARL E. VUONO
General, United States Army
Chief of Staff

Official:

R. L. DILWORTH
Brigadier General, United States Army
The Adjutant General

DISTRIBUTION:

To be distributed in accordance with DA Form 12-25A, Operator, Unit Maintenance requirements for Test Stand, Auto Generator-Alternator Starter and Associated Equipment., GASR-500.

WARNING

HIGH VOLTAGE

is used in--the operation
of this equipment.

DEATH ON CONTACT

may result if personnel fail
to observe safety precautions.
Be careful not to contact high-voltage
connections or 230/460 volt ac input connections
when installing or operating this equipment.

EXTREMELY DANGEROUS POTENTIALS

exist in the following units:
High voltage compartment
Instrument panel assembly, when opened.

ROTATING PARTS

Use of this equipment involves rotating
parts. Be certain that all rotating components
are secure. Failure to observe this warning
may prove fatal.

GAS

When performing tests on AC/DC systems with
external selenium type rectifiers, be cautious not
to apply overvoltage as this will cause a rectifier
breakdown producing a selenium dioxide gas which may
be toxic if inhaled for a period of time. If a disagree-
able odor such as hydrogen sulfide is detected, shut down
test stand and ventilate area. Always disconnect
rectifier from test stand upon completion of tests.

For Artificial Respiration, refer to FM 21-11.

TECHNICAL MANUAL
NO. 9-4910-663-12

HEADQUARTERS
DEPARTMENT OF THE ARMY
WASHINGTON, D.C. 10 June 1981

OPERATOR'S AND ORGANIZATIONAL MAINTENANCE MANUAL

"TEST STAND, AUTOMOTIVE GENERATOR, ALTERNATOR,
STARTER, AND ASSOCIATED EQUIPMENT,
MODEL GASR-500

PART NUMBER 7458-2 (4910-01-041-8161)

PART NUMBER 7458-4 (4910-00-767-0218)

REPORTING ERRORS AND RECOMMENDING IMPROVEMENTS

You can help improve this manual. If you find any mistakes or if you know of a way to improve the procedures, please let us know. Mail your letter, DA Form 2028 (Recommended Changes to Publications and Blank Forms), or DA Form 2028-2 located in back of this manual direct to: Commander, US Army Armament, Munitions, and Chemical Command, ATTN:AMSMC-MAS, Rock Island, IL 61299-6000. A reply will be furnished to you.

| | | Page |
|----------|---|----------|
| CHAPTER | 1. INTRODUCTION | 1-1 |
| Section | I. General | 1-1 |
| | II. Description and data. | 1-1 |
| CHAPTER | 2. OPERATING INSTRUCTIONS. | 2-1 |
| Section | I. Operating procedures | 2-1 |
| | II. Preventive maintenance checks and services | 2-70 |
| | III. Operation of auxiliary equipment | 2-73 |
| | IV. Operation under unusual conditions | 2-73 |
| CHAPTER | 3. OPERATOR/CREW MAINTENANCE INSTRUCTIONS | 3-1 |
| Section | I. Lubrication | 3-1 |
| | II. Troubleshooting | 3-3 |
| | III. Maintenance | 3-3 |
| CHAPTER | 4. ORGANIZATIONAL MAINTENANCE INSTRUCTIONS | 4-1 |
| Section | I. Service upon receipt | 4-1 |
| | II. Lubrication instructions | 4-5 |
| | III. Preventive maintenance checks and services | 4-5 |
| APPENDIX | A. REFERENCES | A-1 |
| | B. COMPONENTS OF END ITEM LIST | B-1 |
| | C. ADDITIONAL AUTHORIZATION LIST | C-1 |
| | D. MAINTENANCE ALLOCATION CHART | D-1 |
| | E. EXPENDABLE SUPPLIES AND MATERIALS LIST | E-1 |
| INDEX | | INDEX- 1 |

Approved for public release; distribution is unlimited.

LIST OF ILLUSTRATIONS

| Figure | Title | Page |
|--------|---|------|
| 1-1. | Test stand front view, showing data plates | 1-3 |
| 1-2. | Test stand rear view, showing data plates | 1-4 |
| 1-3. | High voltage compartment, inside view | 1-6 |
| 2-1. | Instrument and receptacle panels, controls and indicators | 2-2 |
| 2-2. | Control and rheostat panels, controls and indicators | 2-7 |
| 2-3. | Binding post panel, controls and binding posts | 2-11 |
| 2-4. | Timing and drive control panels, controls and indicators | 2-13 |
| 2-5. | High voltage compartment, controls | 2-14 |
| 2-6. | Regulator mounting bracket components | 2-16 |
| 2-7. | Test stand accessories | 2-18 |
| 2-8. | Battery connections | 2-19 |
| 2-9. | Components used for mounting direct driven generators/ alternators (typical) | 2-24 |
| 2-10. | Components used for mounting pulley driven generators/ alternators (typical) | 2-25 |
| 2-11. | Mechanical actuation of lever operated starter start switch | 2-27 |
| 2-12. | Typical system interconnections, 25 ampere DC generator with regulator | 2-52 |
| 2-13. | Typical system interconnections, 100 ampere AC/DC system with voltage regulator and rectifier | 2-53 |
| 2-14. | Typical system interconnections, 300 ampere DC generator- with fan and regulator | 2-54 |
| 2-15. | Typical system interconnections, 100 ampere alternator with rectifier, manual field control | 2-55 |
| 2-16. | Generator connection, 300 ampere, 30 vdc generator (Army P/N 10889713, Lear Siegler G-22-6F-0; Army P/N 10889998, Lear Siegler G-22-7-F-0) | 2-56 |
| 2-17. | Generator connection, 300 ampere, 30 vdc generator (Army P/N 10914831, Lear Siegler G-22-9) | 2-57 |
| 2-18. | Generator connection, 25 ampere, 28 vdc generator (Army P/N 10950808-1, Prestolite GHA-4804UT) | 2-58 |
| 2-19. | Rectifier connection, 100 ampere ac/dc (Army P/N 11640182, Leece Neville C00111100A; Army P/N 7954343, Leece Neville 1029CP; Army P/N 10906314, Leece Neville 1106CA) | 2-59 |
| 2-20. | Voltage regulator connection, 25 ampere, 24 vdc (Army P/N 7351952, Delco Remy 1118424; Army P/N 8360020, Delco Remy 1118656; Army P/N 8712283, Prestolite PRJBC-4004UT; Army P/N 11631857, Vapor 26640473-04) | 2-60 |
| 2-21. | Voltage regulator connection, 25 ampere, 24 vdc (Army P/N 10947439, Vapor 2644001-05) and 100 ampere, 28 vdc (Army P/N 11640367, Leece Neville 91040(5073RB)) | 2-61 |

LIST OF ILLUSTRATIONS (cont)

| Figure | Title | Page |
|--------|--|------|
| 2-22. | Voltage regulator connection, 300 amperes, 28 vdc (Army P/N 11621812, Vapor 26540208-03) | 2-62 |
| 2-23. | Alternator connection, 60 ampere, 28 vdc (Army P/N 10929868, Prestolite AMA-5103UT) | 2-63 |
| 2-24. | Alternator connection, 100 ampere, 28 vdc (Army P/N 11613630, Leece Neville A001-3018-AB) | 2-64 |
| 2-25. | Alternator connection, 100 ampere ac/dc system (Army P/N 10922191, Leece Neville A0015504AB; Army P/N 8376691, Leece Neville A0015320GP; Army P/N 1164980, Leece Neville A0015516AA; Army P/N 7954722, Leece Neville A0015258GS) | 2-65 |
| 2-26. | Alternator connection, 100 ampere, 28 vdc (Army P/N 10947517, Leece Neville A001-2184-AC; Army P/N 10947517, Leece Neville A001-2152-AC) | 2-66 |
| 2-27. | Starter connection, heavy duty (Army P/N 7386254, Bendix EC-3615-1; Army P/N 7539438, Bendix EC-1416-29F; Army P/N 7998649, Lear Siegler 20074-000; Army P/N 7018076, Lear Siegler D42-1-0; Army P/N 7539438, Lear Siegler D42-1-0) | 2-67 |
| 2-28. | Starter connection (Army P/N 10935376, Leece Neville 7072MC; Army P/N 10911018, Delco Remy 1113943; Army P/N 10947131, Delco Remy 1113940; Army P/N 8737705, Delco Remy 1108259; Army P/N 7762618, Delco Remy 1108575; Army P/N 7731426, Delco Remy 1109972; Army P/N 7389561, Delco Remy 1108898; Army P/N 7402334, Delco Remy 1113944; Delco Remy 1113847; Army P/N 10943753, Prestolite MCZ-4111T; Army P/N 10951385-1, Prestolite MFY-6101-1UT; Army P/N 10951385-2, Prestolite MFY-6101-KUT; Army P/N 8712479, Prestolite AL-MEK-6001-AT) | 2-68 |
| 2-29. | Starter connection (Delco Remy 1109045; Army P/N 10951134, Prestolite MBD-4044-UT; Army P/N 7355783, Prestolite AL-MCZ-4002-UT; Army P/N 10945002, Prestolite MDZ-4001-UT; Army P/N 7355782, Prestolite MCZ-4001-UT) | 2-69 |
| 3-1. | Varidrive lubrication chart (part number 7458-2) | 3-4 |
| 3-2. | Varidrive lubrication chart (part number 7458-4) | 3-5 |
| 4-1. | Test stand outline dimensions | 4-3 |
| 4-2. | Power terminal board voltage connections | 4-4 |
| 4-3. | Test stand, front view, major assemblies | 4-6 |
| 4-4. | Test stand, rear view, major assemblies | 4-8 |

CHAPTER 1

INTRODUCTION

Section I. GENERAL

1-1. SCOPE. These instructions are for your use as the operator and organizational maintenance personnel. They apply to the Automotive Generator, Alternator, Starter Test Stand, Model GASR-500, herein referred to as the test stand. Unless otherwise stated, the instructions are applicable to both part numbers covered in this manual.

1-2. MAINTENANCE FORMS AND RECORDS. Maintenance forms, records, and reports that you are required to use are explained in DA PAM 738-750.

1-3. ADMINISTRATIVE STORAGE. The test stand may be placed in administrative storage for a short period of time as authorized by your commanding officer IAW guidance furnished by AR 750-1. Before placing the stand in administrative storage, current maintenance services, shortcomings, and deficiencies should be corrected and all modification work orders (MWOs) should be applied. Storage shall be in a reamer consistent with accepted safety practices and operational requirements.

a. Storage Site. Storage shall be in a covered location free from outside elements such as rain, snow, sand, or dirt. The floor should be a level, hard surface; e.g., wood or concrete.

b. Storage Plan.

(1) Storage shall provide maximum protection from the elements and provide access for inspection and maintenance. Environmental extremes also must be taken into consideration.

(2) The preferable method of storage is to disconnect the stand from power and enclose it in a crate, conex, or similar container which would provide protection from bumping and jarring when nearby equipment is moved. However, as a minimum, power shall be disconnected, and a protective covering shall be provided to protect the stand from dust and excessive moisture.

(3) Storage shall be in a location which will be secure, free from pilferage, tampering, and unauthorized access.

(4) The container or covering enclosing the stand shall be marked so as to readily identify the contents. As a minimum, the NSN and nomenclature shall be clearly marked in locations which are highly visible.

(5) The storage area must have an adequate fire plan and fire-fighting equipment.

(6) The status of the stand shall be periodically monitored to insure the condition of the storage location and stand does not deteriorate.

c. Removal from Administrative Storage. Remove any preservative materials, install, lubricate and prepare the stand for operation in accordance with procedures outlined in this TM.

1-4. DESTRUCTION OF ARMY MATERIAL TO PREVENT ENEMY USE. Destruction of the test stand when subject to capture or abandonment in the combat zone will be undertaken by the using army only when, in the judgement of the unit commander concerned, such action is necessary in accordance with orders of, or policy established by, the Army Commander. Refer to TM 750-244-3 for destruction procedures.

1-5. QUALITY ASSURANCE/QUALITY CONTROL (QA/QC). No requirement for pertinent QA/QC instructions.

1-6. REPORTING QUALITY DEFICIENCY REPORT (QDR). QDRs will be prepared on SF 368, Quality Deficiency Report. Instructions for preparing QDRs are provided in DA PAM 738-750. QDRs should be mailed directly to: Commander, U.S. Army Armament, Munitions, and Chemical Command, ATTN: AMSMC-QAD, Rock Island, IL 61299-6000. A reply will be furnished directly to you.

Section II. DESCRIPTION AND DATA

1-7. DESCRIPTION. The test stand (fig 1-1) is a self-contained unit used for testing, loading, and measuring the electrical output of direct-driven or pulley-drive dc generators, voltage regulators, and ac/dc systems, and for free-run testing of starters. All accessories required for performance of the various tests described in this publication are furnished.

1-8. DATA PLATES.

a. Reversing Switch Caution Plate (1, fig 1-1). This plate cautions the operator not to operate the reversing switch while the vari-drive is in motion.

- b. TACHOMETER RPM Caution Plate (2, fig 1-1). This plate is located directly above the TACHOMETER RPM meter. It cautions the operator not to exceed the maximum speed specified in the test procedure for the item being tested.
- c. Test Stand Data Plate (3, fig 1-1). This plate bears the unit and manufacturer's name, part number, national stock number, serial number, and procurement contract number.
- d. Drive Control Caution Plate (4, fig 1-1). This plate is located on the front of the test stand. It cautions the operator not to engage the START pushbutton longer than 30 seconds.
- e. SPEED CONTROL Stamping (5, fig 1-1). This stamping is located on the outer surface of the SPEED CONTROL handle. It cautions the operator to turn the SPEED CONTROL only when the varidrive is running.
- e.1. Lubrication Point Data Plate (6, fig 1-1). On part number 7458-4, this data plate is located on the front panel of the test stand. It identifies the lubrication fittings.
- f. Low Speed Output Shaft Data Plate (1, fig 1-2). This plate is located on the right drive head of the varidrive (as viewed from the shaft end). It indicates the speed range of 800-4800 revolutions per minute.
- g. Gear Case Oil Level Sight-Gage (2, fig 1-2). This sight-gage is located on the right side of the test stand, directly adjacent to the left drive head. It indicates the oil level to be obtained when filling the gear case with lubricant.
- h. High Speed Output Shaft Data Plate (3, fig 1-2). This plate is located on the left drive head of the varidrive (as viewed from the shaft end). It indicates the speed range of 1,830 to 11,000 revolutions per minute.
- i. Gear Case Lubrication Instruction Plate (4, fig 1-2). This plate is located on the right side of the test stand to the right of the dual head takeoff. It contains lubrication data for the gear case.
- j. Output Shaft, Lubrication Caution Decal (5, fig 1-2). This decal is located on the right side of the test stand, directly on top of the dual head takeoff. It cautions the operator that the test stand is shipped without lubricant in the gear case.
- k. Varidrive Instruction Plates (6 and 7, fig 1-2). These plates are located on the top surface of the varidrive housing. They indicate the varibelt number, lubrication data, operating instructions, and precautionary measures to be observed when operating and maintaining the varidrive.

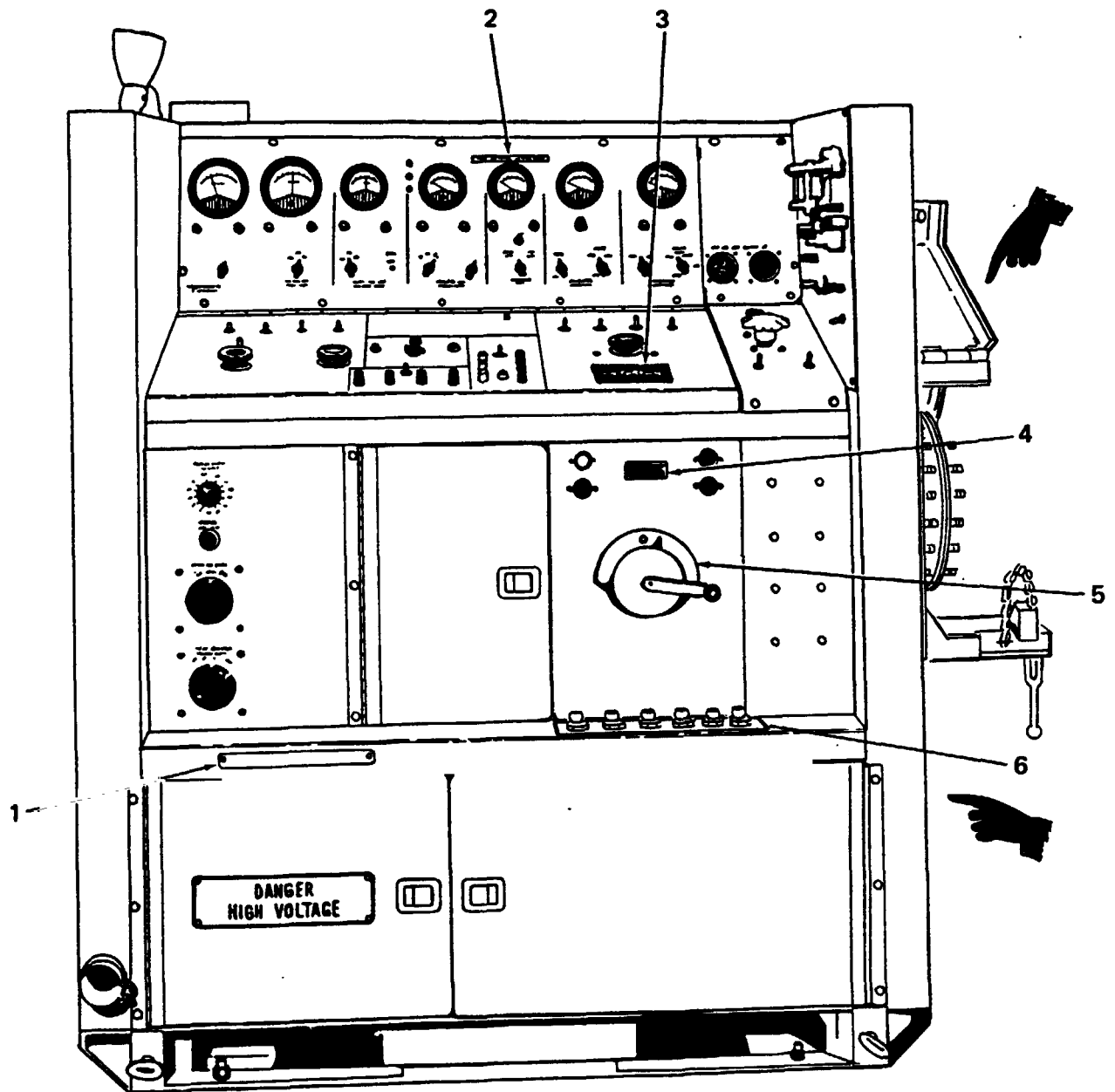

Legend for fig 1-1:

1. Reversing switch caution plate
2. Tachometer rpm caution plate
3. Test stand data plate
4. Drive control caution plate
5. Speed control stamping
6. Lubrication point data plate (part number 7458-4 only)

Figure 1-1. Test stand, front view showing data plates.

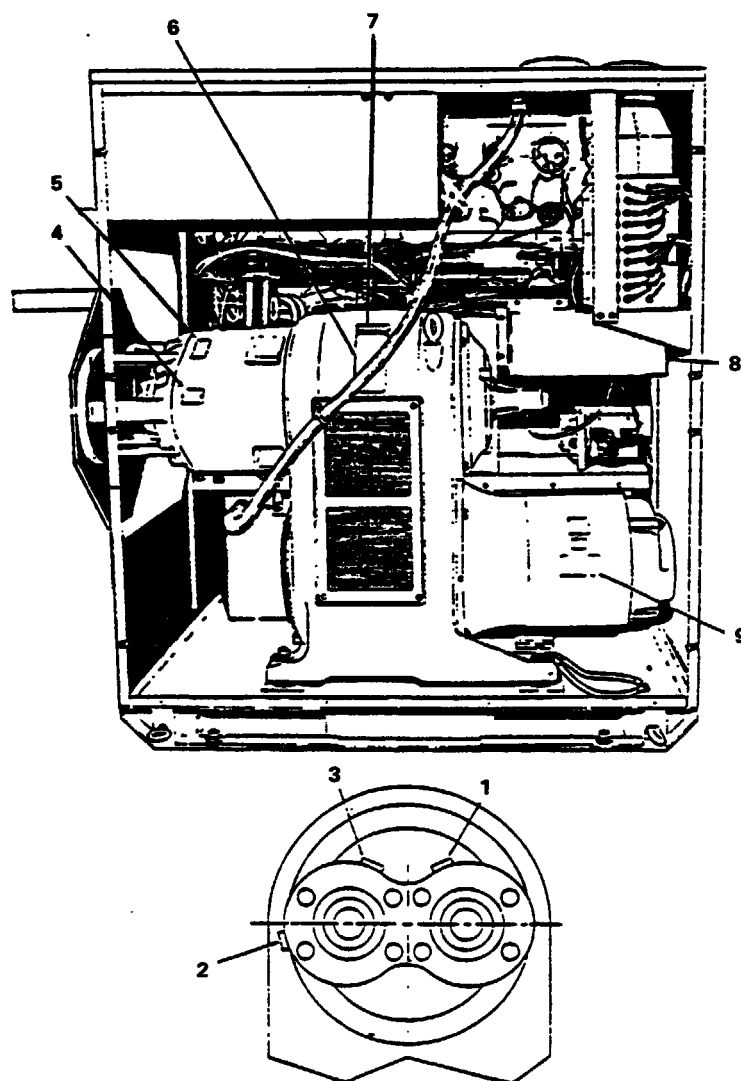

Legend for fig 1-2:

1. Low speed output shaft data plate
2. Gear case oil level sight-gage
3. High speed output shaft data plate
4. Gear case lubrication instruction plate
5. Output shafts lubrication caution decal
6. Varidrive instruction plates
7. Varibelt data plate
8. Blower motor data plate
9. Varidrive motor data plate

Figure 1-2. Test stand, rear view, showing data plates.

l. Blower Motor Data Plate (8, fig 1-2). This plate is located on the end bell of the blower motor. It indicates the electrical characteristics of the motor, frame, style, serial number, and manufacturer's name and address.

m. Varidrive Motor Data Plate (9, fig 1-2). This plate is located on the stator housing of the varidrive motor. It indicates the electrical characteristics of the motor and the manufacturer's name and address.

n. Motor Starter Data Plate (fig 1-3). This plate is mounted on the front of the motor starter, which is located in the high voltage compartment. The plate indicates the electrical characteristics of the motor starter and the manufacturer's name and address.

1-9. TABULATED DATA

a. Test Stand.

| | |
|------------------------------|---|
| Manufacturer | UMC Electronics Company |
| Model | GASR-500 |
| Weight (w/equipment) | 2500 pounds |
| Cubage (packed for shipment) | 112.28 cubic feet |
| Height | 62 inches |
| Length | 65 inches |
| Width | 44 inches |
| Low speed head | 800 to 4800 rpm |
| High speed head | 1830 to 11,000 rpm |
| Input power | 230/460 volts, 3 phase, 60 Hz |
| Cooling | Forced air, inlet blower |
| Ducting | 6-inch inlet and exhaust for blower; 1-inch vent for battery fumes. |

b. Varidrive.

| | |
|---------------------------|------------------------|
| Manufacturer | U.S. Electrical Motors |
| Horsepower (continuous) | 22.5 |
| Horsepower (intermittent) | 35 |
| Voltage | 230/460 ac, 3 phase |
| Frequency | 60 Hz |
| Speed | 800 - 11,000 rpm |
| Phase | 3 |
| Amperes (440 volts) | 34 |
| Amperes (220 volts) | 68 |
| Temperature rise | 158°F (70°C) |
| Frame | 55-286T-51Y |
| Type | VEU-RF-GSDT |
| Code | K |
| Design | B |
| Gear ratios | 1.12:1, 2.62:1 |

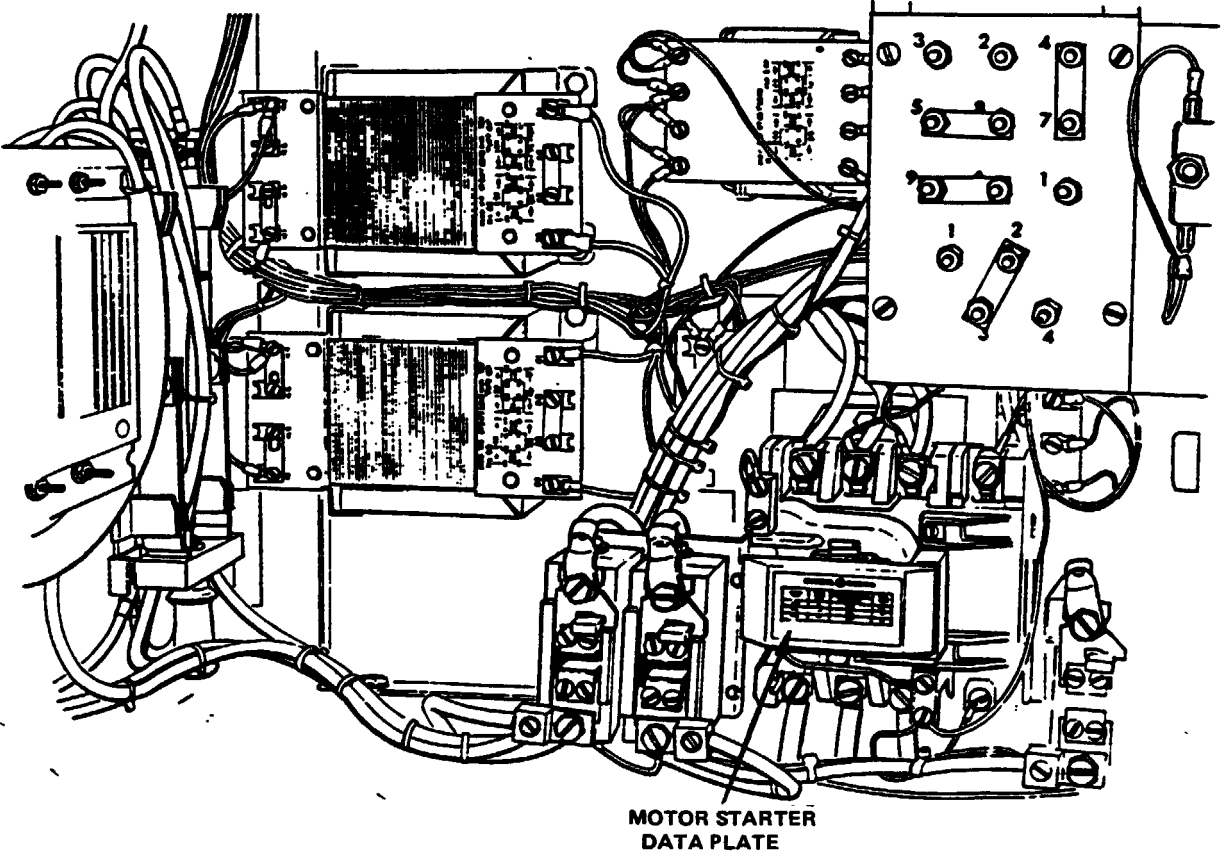

Figure 1-3. High voltage compartment, inside view.

CHAPTER 2
OPERATING INSTRUCTIONS

NOTE

If equipment fails to operate, refer to troubleshooting (chapter 3, section II).

Section I. OPERATING PROCEDURES

2-1. GENERAL. This section provides information pertaining to instruments provided for operation of the test stand, together with operating instructions for the test stand.

2-2. INSTRUMENTS AND CONTROLS. The following paragraphs contain the information pertaining to the instruments and controls (controls and indicators) of the test stand.

a. Instrument Panel.

(1) DC AMMETER LOAD & STARTER OUTPUT CURRENT BATTERY CHARGE CURRENT Binding Posts (fig 2-1). These binding posts, which are connected directly to the meter terminals, are for test and calibration only.

(2) DC AMMETER LOAD & STARTER OUTPUT CURRENT BATTERY CHARGE CURRENT Meter (M3, fig 2-1). This meter has a scale of 15-0-50 amperes dc (direct current) and a movement of 15-0-50 millivolts dc. It is used with five external 50 millivolt dc shunts to measure dc currents in ranges of XI (50 amperes), X3 (150 amperes), X10 (500 amperes), and X4 (200 amperes).

(3) DC AMMETER FIELD CURRENT Binding Posts (fig 2-1). These binding posts, which are connected directly to the terminals of the associated meter, are for test and calibration only.

(4) DC AMMETER FIELD CURRENT Meter (M7, fig 2-1). This meter has a scale of 5-0-5 dc amperes, and a movement of 50-0-50 millivolts dc. It is used with three external 50 millivolt shunts to measure dc currents in ranges of XI (5 amperes), X3 (15 amperes), and X6 (30 amperes). The currents that are measured are developed in the field circuits of generators or alternators undergoing test.

(5) MILLIVOLT METER MILLIVOLT DROP Binding Posts (fig 2-1). These binding posts, which are connected directly to the terminals of the associated meter, are for test and calibration only.

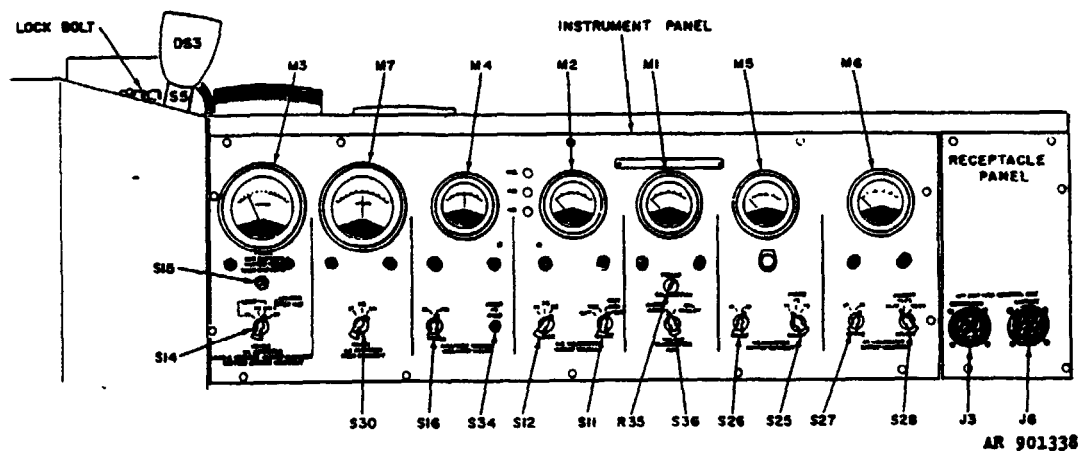

Legend for fig 2-1:

- J3 Connector
- J6 Connector
- M1 Tachometer RPM Meter
- M2 DC Voltmeter Output Voltage Meter
- M3 DC Ammeter Load & Starter Output Current Battery Charge Current Meter
- M4 Millivolt Meter Millivolt Drop Meter
- M5 AC Ammeter Output Current Meter
- M6 AC Voltmeter Output Voltage Meter
- M7 DC Ammeter Field Current Meter
- R35 Tachometer RPM Pulley Calibration Control
- S11 DC Voltmeter Output Voltage Select Switch
- S12 DC Voltmeter Output Voltage Range Switch
- S14 DC Ammeter Load and Starter Output Current Battery Charge Current Range Switch
- S15 DC Ammeter Load and Starter Output Current Battery Charge Current Press for Battery Charge Rate Switch
- S16 Millivolt Meter Millivolt Drop Range Switch
- S25 AC Ammeter Output Current Select Switch
- S26 AC Ammeter Output Current Range Switch
- S27 AC Voltmeter Output Voltage Range Switch
- S28 AC Voltmeter Output Voltage Select Switch
- S30 DC Ammeter Field Current Range Switch
- S34 Millivolt Meter Millivolt Drop Press to Read Switch
- S36 Tachometer RPM Select Switch

Figure 2-1. Instrument and receptacle panels, controls and indicators.

(6) MILLIVOLT METER MILLIVOLT DROP Meter (M4, fig 2-1). Dc volts or dc millivolts are measured by this meter, which has a scale of 900-0-900 millivolts dc. This meter is used with external resistors and potentiometers (on the printed circuit card), which are used to calibrate the meter. Common terminals are provided for the 900 millivolt and 9 volt circuits. The meter is used to measure the voltage difference between generator or regulator G+ and regulator B+ binding posts (fig 2-3), and to check the voltage drop across relay contacts.

(7) DC VOLTMETER OUTPUT VOLTAGE Binding Posts (fig 2-1). These binding posts, which parallel the associated meter circuit, are for test and calibration only.

(8) DC VOLTMETER OUTPUT VOLTAGE Meter (M2, fig 2-1). This meter has a scale of 0-10 volts dc and has common binding posts for the ranges of 10, 20, and 50 volts dc. External multiplier resistors are provided on the printed circuit board for the different ranges.

(9) TACHOMETER RPM Binding Posts (fig 2-1). These binding posts, which are connected directly to the terminals of the associated meter, are for test calibration only.

(10) TACHOMETER RPM Meter (M1, fig 2-1). The TACHOMETER RPM meter is a two scale meter that is used to indicate the drive speed of the unit undergoing test. The indications on the two scales, which are marked 0 to 5.1 and 0 to 12, must be multiplied by 1000 to obtain the correct rpm indications. The scale to be read is determined by the output shafts on which the unit undergoing test is mounted.

(11) AC AMMETER OUTPUT CURRENT Jack (fig 2-1). This jack, which is connected in series with the corresponding meter, is for test and calibration only.

(12) AC AMMETER OUTPUT CURRENT Meter (M5, fig 2-1). This meter is an ac meter with a range of 0-100 amperes. It is used with three tapped current transformers to measure output currents of alternators undergoing test. Taps on the current transformers provide two ranges of 0 to 100 amperes and 0 to 500 amperes.

(13) AC VOLTMETER OUTPUT VOLTAGE Binding Posts (fig 2-1). These binding posts, which are connected directly to the terminals of the associated meter, are for test and calibration only.

(14) AC VOLTMETER OUTPUT VOLTAGE Meter (M6, fig 2-1). This is an ac voltmeter with a scale of 0 to 25 volts ac. It is used with multiplier resistors to measure ac voltages in ranges of 0 to 25 volts and 0 to 50 volts ac.

(15) AC VOLTMETER OUTPUT VOLTAGE SELECT Switch (S28, fig 2-1). This switch, which has three positions designated T1-T2, T1-T3, and T2-T3, is used to connect the AC VOLTMETER OUTPUT VOLTAGE meter circuits-for measurement of desired ac phase voltages.

(16) AC VOLTMETER OUTPUT VOLTAGE RANGE Switch (S27, fig 2-1). This switch has two positions: X1 (25 volts), direct to the corresponding meter, and X2 (50 volts), to an external multiplier resistor mounted on the printed circuit board. The switch provides a means of selecting either of the two ranges of the AC VOLTMETER OUTPUT VOLTAGE meter.

(17) AC AMMETER OUTPUT CURRENT SELECT Switch (S25, fig 2-1). This switch connects the AC AMMETER OUTPUT CURRENT meter circuit to the desired phase (T1, T2, or T3) to be monitored, and maintains a shorted condition across the secondaries of the other two phase current transformers.

(18) AC AMMETER OUTPUT CURRENT RANGE Switch (S26, fig 2-1). This switch has two positions: X1 (100 amperes) and X5 (500 amperes). The switch provides a means of selecting either of two ranges of the AC AMMETER OUTPUT CURRENT meter.

(19) TACHOMETER RPM SELECT Switch (S36, fig 2-1). This switch is a selector switch for the TACHOMETER RPM meter. The DIRECT DRIVE position is used when the unit undergoing test is a direct driven unit, or a pulley-driven unit with a 1:1 pulley ratio with the test stand. The CAL PULLEY position is used when the unit undergoing test is a pulley-driven unit with a pulley diameter that differs from that of the test stand.

(20) TACHOMETER RPM PULLEY CALIBRATION Control (R35, fig 2-1). This control is used to calibrate the TACHOMETER RPM meter circuit to provide the correct speed indication for pulley-driven units having a pulley diameter that differs from that of the test stand. Use of this control is described in paragraph 2-5b.

(21) DC VOLTMETER OUTPUT VOLTAGE SELECT Switch (S11, fig 2-1). This switch provides a means for using the DC VOLTMETER OUTPUT VOLTAGE meter for measurement of dc voltages at different points in the test circuit, as follows:

(a) The BAT position connects the meter circuit to the B+ bus and the battery minus bar, when the MASTER LOAD DISCONNECT switch is in the ON position.

(b) The VAR position connects the meter circuit to the output terminals of the dc variable volts circuit to measure the output voltage of this circuit. When DC VOLTMETER OUTPUT VOLTAGE SELECT switch (S11, fig 2-1) is set to VAR, the corresponding meter can be used to measure dc voltages as applied with the DC VARIABLE POWER SUPPLY 0-32 VDC (T5, fig 2-4) and DC VARIABLE VOLT switch (S10, fig 2-2) is placed to ON position.

(c) The RECT GEN position connects the meter circuit to G+ and G- circuits of a dc generator test circuit, or to the plus and minus outputs of the rectifier when ac ac/dc system is being tested.

(d) The EXT position connects the meter circuit to external dc voltmeter binding posts (fig 2-2) to permit use of the meter for measurement of dc voltages from sources outside the test stand.

(22) DC VOLTMETER OUTPUT VOLTAGE RANGE Switch (S12, fig 2-1). This switch provides a means for selecting the desired range of the associated meter, as required for the test being performed. The switch positions are X1 (10 volts), X2 (20 volts), and X5 (50 volts), with the multipliers applying to the meter scale indications.

(23) MILLIVOLT METER MILLIVOLT DROP PRESS TO READ Switch (S34, fig 2-1). This switch, when actuated, connects the corresponding meter to the test circuit. The switch is normally spring-loaded to the off position to prevent the application of voltage to the meter. A back-to-back diode prevents damage to the meter from momentary overload.

(24) MILLIVOLT METER MILLIVOLT DROP RANGE Switch (S16, fig 2-1). This switch is used to select either the X1 (900 millivolt) or X10 (9 volt) range of the associated meter, depending upon test requirements.

(25) DC AMMETER FIELD CURRENT RANGE Switch (S30, fig 2-1). This switch is used to select the desired range of the associated meter. This is accomplished by connecting the meter across the appropriate external 50 millivolt shunt. This switch provides for the selection of three ranges: X1 (5-0-5 amperes), X3 (15-0-15 amperes), and X6 (30-0-30 amperes).

(26) DC AMMETER LOAD & STARTER OUTPUT CURRENT BATTERY CHARGE CURRENT RANGE Switch (S14, fig 2-1). This switch is used to select the desired range of the associated meter. This is accomplished by connecting the proper 50 millivolt shunt to the meter.

(27) DC AMMETER LOAD & STARTER OUTPUT CURRENT BATTERY CHARGE CURRENT PRESS FOR BATTERY CHARGE RATE Switch (S15, fig 2-1). This momentary switch, when pressed, connects the associated meter across a 50 millivolt shunt in the battery charge circuits of the test stand to measure battery charging current.

b. Control Panel.

(1) EXTERNAL FIELD EXCITER AC SYSTEM Switch (S31, fig 2-2). This switch is used in conjunction with the MANUAL position of FIELD CIRCUIT switch (S32, fig 2-2). When set to ON, it selects external exciter control for the field of the ac system undergoing test.

(2) GENERATOR FIELD Switch (S37, fig 2-2). This switch provides means for selecting either internal or external grounding for the field of the unit undergoing test.

(3) POLARITY REVERSING Switch (S7, fig 2-2). This switch provides means for actuating relays in the test stand as required to accommodate generators with negative or positive grounds.

(4) FIELD CIRCUIT Switch (S32, fig 2-2). This switch selects the type of control of field current for the unit undergoing test. In the MANUAL position, field current is adjusted by means of the test stand rheostat (R26, R27, fig 2-2). In the REGULATOR position, field current is regulated by an external regulator.

(5) 6 VOLT Indicator Light (DS4, fig 2-2). This 6 VOLT indicator light will illuminate whenever the BATTERY CURRENT SELECTOR switch (S6, fig 2-2) is positioned to the 6V position.

(6) CIRCUIT BREAKERS (CB2 thru CB9 and CB11, fig 2-2). These circuit breakers control application of ac or dc power to various circuits of the test stand, as follows:

(a) CB7 controls application of ac power to the dc variable volts circuits, and provides protection for the ac power circuits.

(b) CB2 controls application of ac power to all test stand circuits except the varidrive and blower, and provides protection for the 110-volt control circuits of the test stand.

(c) CB9 controls application of dc output voltage of the dc variable volts circuit to the test circuits, and provides protection for these dc output circuits.

(d) CB5 controls application of ac power to the relay control circuits, and provides protection to the dc relay control power circuits of the test stand.

(e) CB3 controls application of ac power to the blower motor (4, fig 4-4), and provides protection to the blower motor.

(f) CB6 controls application of ac power to the battery charging circuits, and provides protection for these ac power circuits.

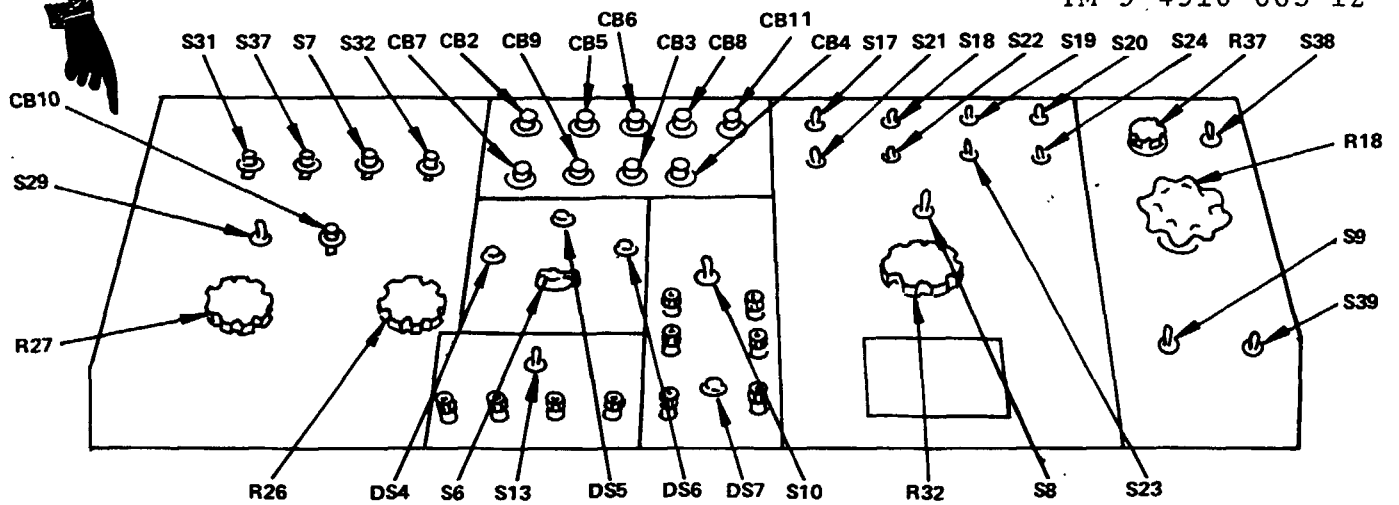

Legend for fig 2-2:

- CB2 Circuit Breaker
- CB3 Circuit Breaker
- CB4 Circuit Breaker
- CB5 Circuit Breaker
- CB6 Circuit Breaker
- CB7 Circuit Breaker
- CB8 Circuit Breaker
- CB9 Circuit Breaker
- CB10 Circuit Breaker
- CB11 Circuit Breaker
- DS4 6 Volt Indicator Light
- DS5 12 Volt Indicator Light
- DS6 24 Volt Indicator Light
- DS7 Contact Closure Indicator Light
- R18 Starter Rheostat Control
- R26 Field Current 0-30 Amps (Max) Control
- R27 Field Current 0-5 Amp (Max) Control
- R32 Variable Load Control
- R37 Voltage ADJ Control
- S6 Battery Circuit Selector Switch
- S7 Polarity Reversing Switch
- S8 Master Load Disconnect Switch
- S9 Starter Test Switch
- S10 DC Variable Volts Switch
- S13 Regulator Check Fixed Resistance Method Switch
- S17 Load Selection Switch
- S18 Load Selection Switch
- S19 Load Selection Switch
- S20 Load Selection Switch
- S21 Load Selection Switch
- S22 Load Selection Switch
- S23 Load Selection Switch
- S24 Load Selection Switch
- S29 Fine Control 0-5 Amps (Max) Switch
- S31 External Field Exciter AC System Switch
- S32 Field Circuit Switch
- S37 Generator Field Switch
- S38 Field Shorting Switch
- S39 AUX Start Switch

Figure 2-2. Control and rheostat panels, controls and indicators.

(g) CB4 controls application of ac power to the blower motor (4, fig 4-4), and provides protection to the the blower motor.

(h) CB8 controls application of dc voltage to batteries undergoing charge, and provides protection for the dc circuits of the battery charge section of the test stand.

(i) CB11 limits maximum current from the generator under test to the battery of reverse battery current to 50 amperes.

(7) LOAD SELECTION Switches (S17 thru S24, fig 2-2). These switches are used to select loads to be applied to the unit undergoing test. These switches are effective only if MASTER LOAD DISCONNECT switch (S8, fig 2-2) is set to ON.

(8) MASTER LOAD DISCONNECT Switch (S8, fig 2-2). This switch, when set to OFF, disconnects all loads from the unit undergoing test; when set to ON, applies loads preset by LOAD SELECTION switches to unit undergoing test.

(9) VARIABLE LOAD Control (R32, fig 2-2). This control is used for fine load adjustment between the step values available through use of the LOAD SELECTION switches. (LOAD SELECTION switch (S24) must be set to ON for this control to operate.)

(10) DC VARIABLE VOLTS Switch (S10, fig 2-2). This switch controls application of the dc variable volts output of the test stand to the unit under test and to the DC VARIABLE VOLTS OUTPUT binding posts (fig 2-2).

(11) DC VARIABLE VOLTS OUTPUT Binding Posts (fig 2-2). The output voltage of the test stand dc variable volts supply is available at these binding posts for measurement or application to an external point.

(12) EXTERNAL DC VOLTAGE INPUT Binding Posts (fig 2-2). When DC VOLTMETER OUTPUT VOLTAGE SELECT switch (S11, fig 2-1) is set to EXT, the corresponding meter can be used to measure dc voltages at points external to the test stand. These binding posts provide means for connecting the meter circuit to the external source whose dc voltage is to be measured.

(13) RELAY CONTACTS INPUT Binding Posts (fig 2-2). These binding posts provide means for connecting external relay contact circuits to the test stand for testing.

(14) CONTACT CLOSURE Indicator Light (DS7, fig 2-2). This indicator is used when checking relay contacts to indicate opening and closing of the contacts.

(15) 7 OHM Binding Post (below S13, fig 2-2). This binding post is used when performing regulator fixed resistance checks to apply the 7 ohms of fixed resistance to the unit undergoing test.

(16) 24 VOLT Indicator Light (DS6, fig 2-2). This 24 VOLT indicator light will illuminate whenever the BATTERY CIRCUIT SELECTOR switch (S6, fig 2-2) is positioned to the 24 V position.

(17) 2 1/4 OHM Binding Post (below S13, fig 2-2). This binding post is used when performing regulator fixed resistance checks to apply 2 1/4 ohms of fixed resistance to the unit undergoing test.

(18) REGULATOR CHECK FIXED RESISTANCE METHOD Switch (S13, fig 2-2). This switch, when set to ON, completes test stand circuit connections for fixed resistance checks of a regulator.

(19) 1 1/2 OHM Binding Post (below S13, fig 2-2). This binding post is used when performing regulator fixed resistance checks to apply 1 1/2 ohms of fixed resistance to the unit undergoing test.

(20) BATTERY CIRCUIT SELECTOR Switch (S6, fig 2-2). This switch provides a means for selecting the battery voltage (6, 12, or 24 volts dc) to be used for testing of starters, generators, and regulators.

(21) 1/4 OHM Binding Post (below S13, fig 2-2). This binding post is used when performing regulator fixed resistance checks to apply 1/4 ohm of fixed resistance to the unit undergoing test.

(22) 12 VOLT Indicator Light (DS5, fig 2-2). This 12 VOLT indicator light will illuminate whenever the BATTERY CIRCUIT SELECTOR switch is positioned to the 12 V position.

(23) FIELD CURRENT 0-30 AMPS (MAX) Control (R26, fig 2-2). This control provides means for adjustment of field current of generators undergoing test when the FIELD CIRCUIT switch is set to the MANUAL position.

(24) CB10 FINE CONTROL Circuit Breaker (fig 2-2). This circuit breaker connects FIELD CURRENT 0-5 AMPS (MAX) control (R27, fig 2-2) into the field supply circuit for the unit undergoing test to provide fine control of field current. FINE CONTROL 0-5 AMPS (MAX) switch (S29, fig 2-2) must be set to ON for the FIELD CURRENT control (R26, fig 2-2) to operate. Circuit breaker (CB10) protects against excessive field currents.

c. Binding Post Panel.

(1) REGULATOR Binding Posts (fig 2-3). These binding posts (D, GND, F-B, G+, B+, G-, and B-) provide means for connecting a regulator to the test stand for performance of voltage regulator testing, generator testing, or regulator/generator system testing.

(2) STARTER Binding Posts (fig 2-3). These binding posts STARTER COMMON, STARTER FREE-RUN, and STARTER INPUT provide means for connecting a starter to the test stand for free-running testing.

(3) ALTERNATOR Binding posts (fig 2-3). Binding posts T1, T2, and T3 provide means for connecting the ac output of an alternator that is to undergo test to the test stand. Binding posts D and E provide means for connecting the field circuit of an alternator that is to undergo test to the test stand.

(4) GENERATOR Binding Posts (fig 2-3). The binding posts G+ and G-, provide means for connecting the armature circuit of a generator that is to undergo test to the test stand. Binding post D is used to connect the generator equalizer circuit, if applicable, to the test stand and also to the generator corresponding voltage regulator. Binding post F is used to interconnect the shunt field of a generator undergoing test to the test stand.

(5) D-SENSING Switch (S40, fig 2-3). This switch is normally set to the ON position (for all normal testing) except when required to perform fail-safe test when interpole lead is broken as required on certain voltage regulators.

(6) AC/DC SYSTEMS Switches and Binding Posts (fig 2-3). IGN SW switch (S33) is used when testing some types of ac/dc alternator/rectifier systems for energizing the regulator load contactor. EQUALIZER COIL TEST switch (S35) is used when testing those voltage regulators used on parallel generator systems. When the EQUALIZER COIL TEST switch is set to ON, it applies a predetermined voltage across the regulator equalizer coil, thereby reducing the generator output voltage by a specified amount. IGN SW binding post provides means for connecting the ignition switch input to certain types of ac/dc alternator/rectifier systems during testing. Alternator E and D binding posts provide means for connecting the voltage regulator into the test circuit when testing ac/dc alternator systems.

d. Rheostat Panel.

(1) VOLTAGE ADJ Control (R37, fig 2-2). This control provides means for adjusting the output voltage of the generator undergoing test when used with specific types of voltage regulators.

(2) FIELD SHORTING Switch (S38, fig 2-2). This momentary switch, when pressed, shorts the field control circuit of a generator voltage regulator undergoing test; it is used during specific tests on some generator control boxes.

(3) STARTER RHEOSTAT Control (R18, fig 2-2). This control is used to adjust the input voltage to a starter undergoing test.

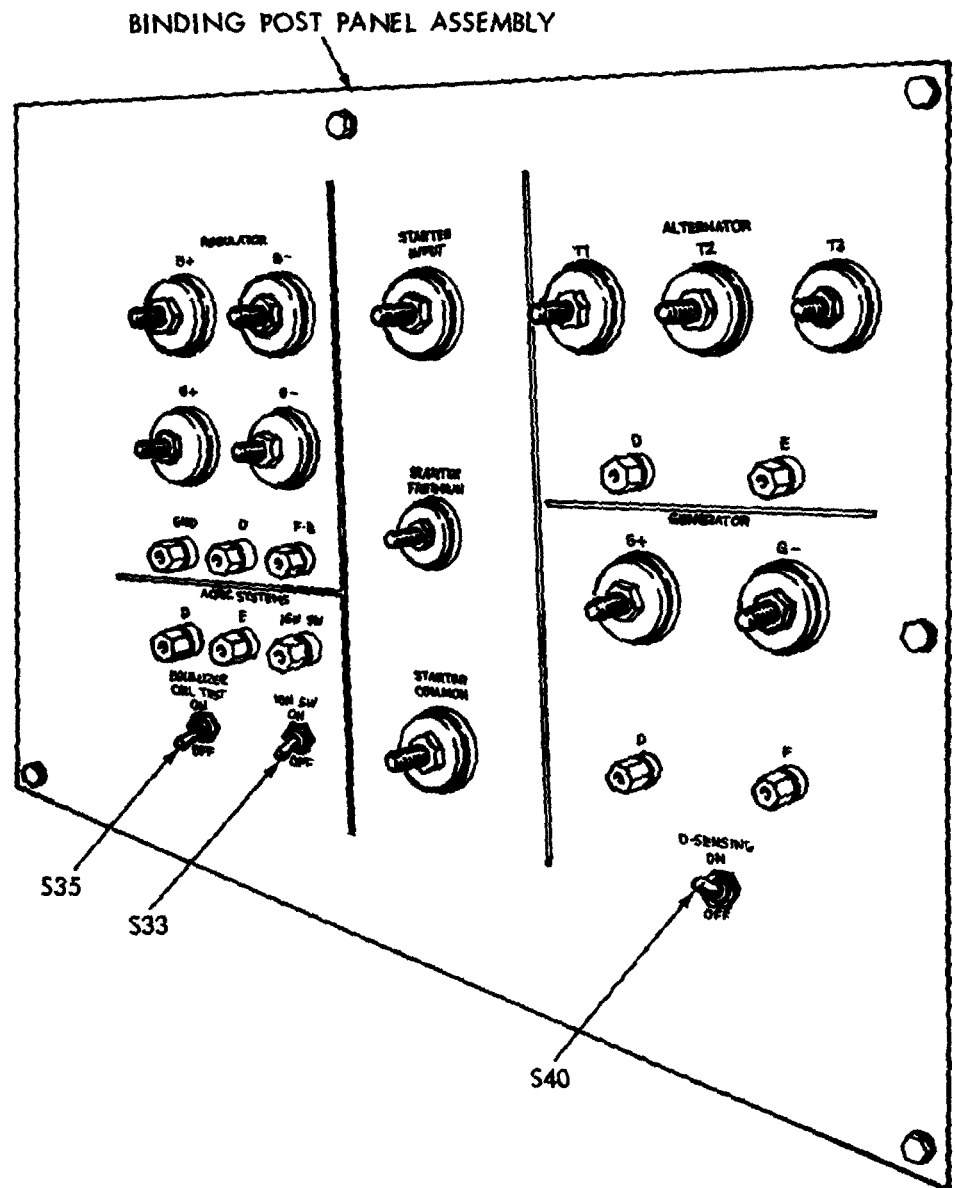

AR901340

Legend for fig 2-3:

- S33 IGN SW Switch
- S35 Equalizer Coil Test Switch
- S40 D Sensing Switch

Figure 2-3. Binding post panel, controls and binding posts.

TM 9-4910-663-12

(4) AUX START Switch (S39, fig 2-2). This momentary switch is used to test the auxiliary start circuitry of certain generator control boxes.

(5) STARTER TEST Switch (S9, fig 2-2). This switch controls application of battery voltage to a starter undergoing test.

e. Timer Panel.

(1) DC VARIABLE POWER SUPPLY 0-32 VDC Control (T5, fig 2-4). This control is used to adjust the output voltage of the dc variable power supply in the test stand.

(2) BATTERY CHARGE CIRCUIT Control (T3, fig 2-4). This control adjusts the dc charge current for the battery charging circuits.

(3) CHARGE INDICATOR Light (DS8, fig 2-4). This light, when lighted, indicates that ac power is being applied to the battery charging circuits-of the test stand.

(4) CHARGE TIMER (MINUTES) Control (TD1, fig 2-4). This control is used to set the charge time (120 minutes maximum) when the test stand is being used for battery charging.

f. Drive Control Panel.

(1) START Pushbutton Switch (S3, fig 2-4). This switch is used to start the varidrive and loadbank cooling air blower.

(2) AC POWER ON Indicator Light (DS2, fig 2-4). This indicator light, when lighted, indicates that primary ac power is being applied to the test stand power circuits.

(3) SPEED CONTROL (fig 2-4). This control is used to adjust the speed of the varidrive.

(4) DRIVE ON Indicator Light (DS1, fig 2-4). This indicator light, when lighted, indicates that ac input power is being applied to the varidrive.

(5) STOP Pushbutton Switch (S2, fig 2-4). This switch is used to stop the varidrive and loadbank cooling air blower.

WARNING

HIGH VOLTAGES/HIGH AMPERES

High voltages and high amperes are contained within the high voltage panel. Voltage and amperes may be sufficient to cause DEATH.

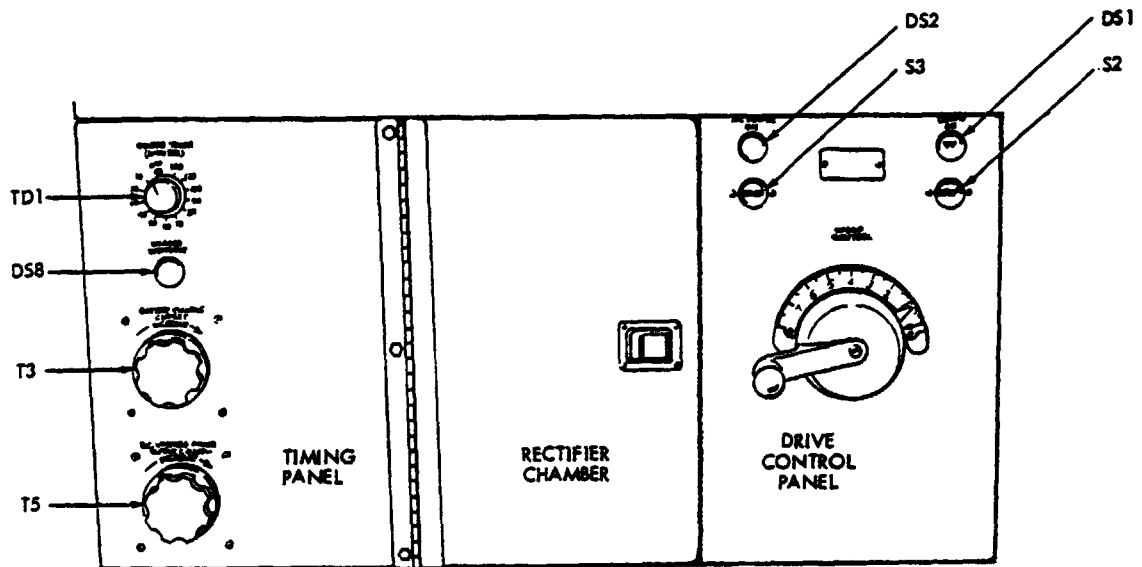

AR 901341

Legend for fig 2-4:

- DS1 Drive On Indicator Light
- DS2 AC Power On Indicator Light
- DS8 Charge Indicator Light
- S2 Stop Pushbutton Switch
- S 3 Start Pushbutton Switch
- T3 Battery Charge Circuit Control
- T5 DC Variable Power Supply 0-32 VDC Control
- TD1 Charge Timer (Minutes) Control

Figure 2-4. Timing and drive control panels, controls and indicators.

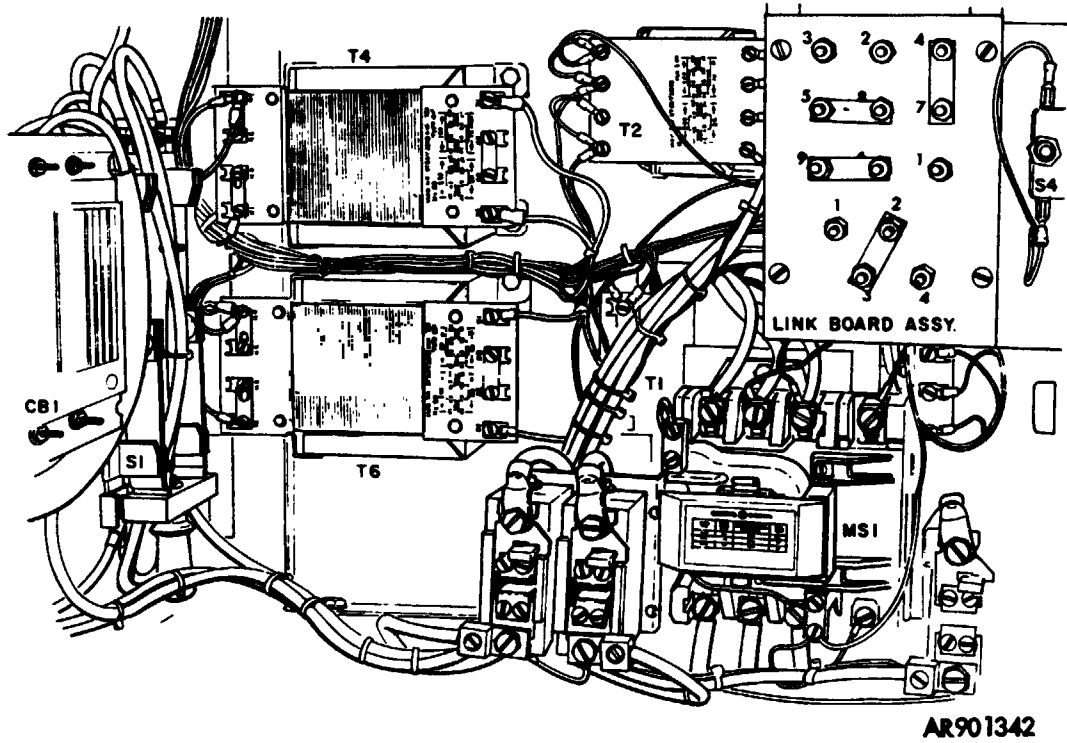

Legend for fig 2-5:

- | | |
|-----|-----------------------------|
| CB1 | Circuit Breaker Switch |
| MS1 | Drive Magnetic Starter Coil |
| S1 | Reversing Switch |
| S4 | Interlock Switch |
| T1 | Power Transformer |
| T2 | Power Transformer |
| T4 | Power Transformer |
| T6 | Power Transformer |

Figure 2-5. High voltage compartment controls.

g. High Voltage Compartment.

(1) Circuit Breaker Switch (CB1, fig 2-5). This circuit breaker controls application of primary ac power to the test stand.

(2) Reversing Switch (S1, fig 2-5). This switch is used to reverse the direction of rotation of the varidrive.

(3) Link Board Assembly (fig 2-5). This board sets up the input power.

(4) Interlock Switch (S4, fig 2-5). This is the interlock safety switch.

2-3. PREPARATION FOR OPERATION. Prepare the test stand for operation as follows:

a. Check the gear case oil level (level with the oil level indicator (11, fig 3-1) on the test stand side panel). If necessary, fill the gear case with lubricant to that level.

b. Remove equipment that has been placed in the rectifier chamber (6, fig 4-3) and the high voltage compartment (5, fig 4-3).

c. Check the readings of all seven instrument panel meters (M1 thru M7, fig 2-1). All meters should indicate 0. Zero adjust the meter pointers, if necessary, by turning the adjustment screw located at the center of the meter directly below the glass. Turning the adjustment screw clockwise moves the pointer to the right, and turning the adjustment screw counterclockwise moves the pointer to the left.

CAUTION

Do not overadjust the meter pointers. Damage may result if this precaution is not observed.

d. When testing a voltage regulator in conjunction with a generator, be sure that the unit is properly and securely mounted on the test stand (fig 2-6).

e. Use only the proper adapters, mounting flange adapter, cables, and pulleys that are included in test stand accessories (fig 2-7), to perform a test.

f. Before mounting generators or starters on the test stand, make sure that the varidrive output shafts (1, 3, fig 1-2) are not rotating.

g. Check all controls to make sure that they are set to the positions specified in table 2-1. Give special attention to BATTERY CIRCUIT SELECTOR switch (S6, fig 2-2).

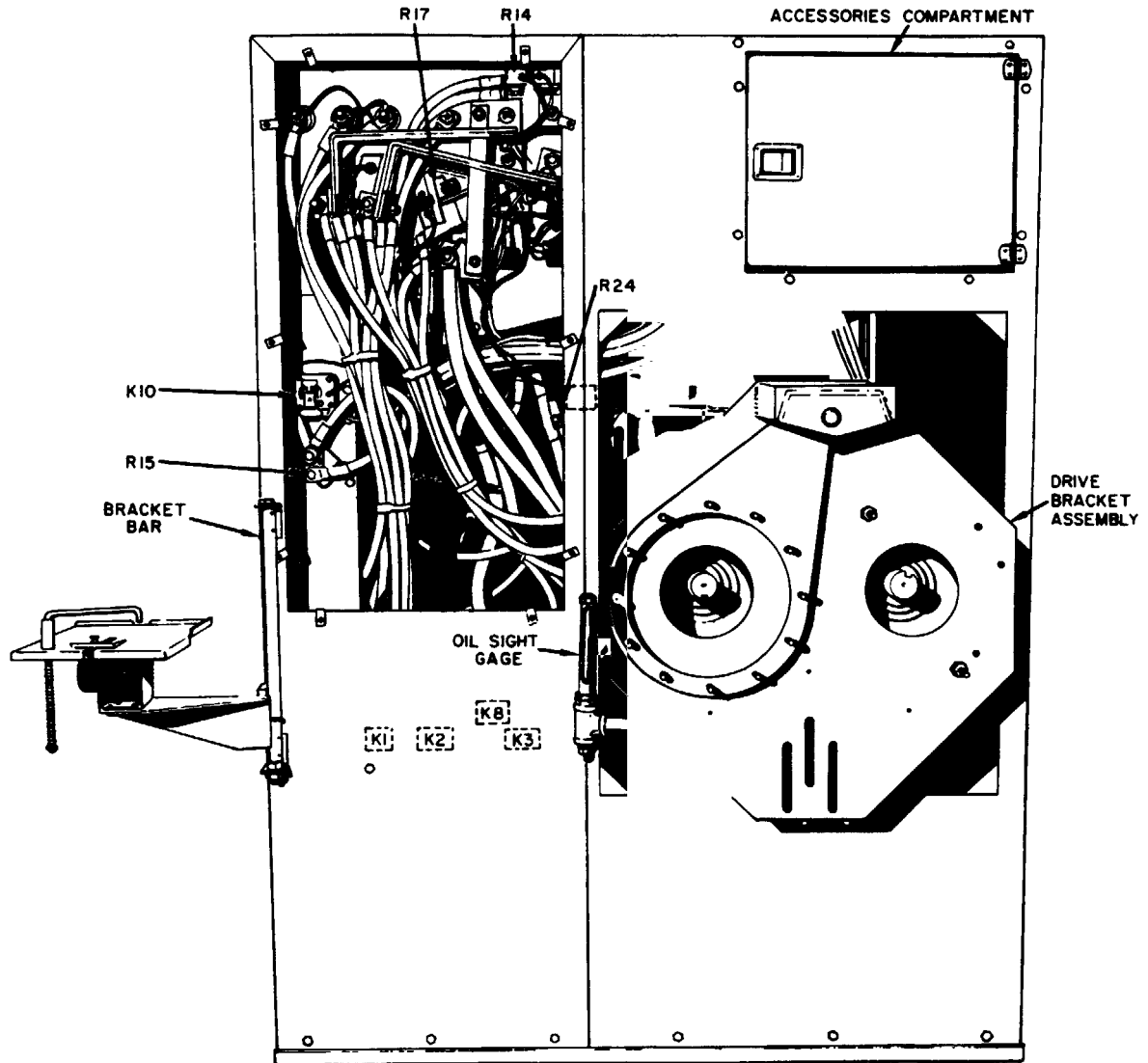

Legend for fig 2-6:

AR912363

- | | |
|-----|----------------------------|
| K1 | Relay |
| K2 | Relay |
| K3 | Relay |
| K8 | Relay |
| K10 | Relay |
| R14 | Shunt |
| R15 | Shunt |
| R17 | Shunt |
| R24 | Equalization Coil Resistor |

Figure 2-6. Regulator mounting bracket components.

CAUTION

If the BATTERY CIRCUIT SELECTOR switch is set to the ON position while testing a generator, the generator can be motorized.

h. Install batteries into the battery compartment (4, fig 4-3). Provisions are included for the installation of four 6-volt batteries or two 6-volt batteries and one 12-volt battery; two 12-volt batteries; or one 24-volt battery. Refer to fig 2-8 for cabling information. The use of four 6-volt batteries or two 6-volt batteries and one 12-volt battery allows for battery voltage selection of 6, 12, or 24 volts.

2-4. MOUNTING OF COMPONENTS TO BE TESTED. The following paragraphs contain the instructions to mount the component to be tested.

a. Mounting Direct Driven Generator/Alternators (fig 2-9).

(1) On part number 7458-4, raise the hinged output shaft guards on the test stand. Position the pivot arm (1) to the drive output shaft (1, 3, fig 1-2) desired, depending upon the speed range of the generator/alternator. To swing the pivot arm (1) from one output shaft to the other, remove the two 3/8-24 nuts which secure the pivot arm (1) to the hex locating studs (2) and slide entire assembly away from the drive output shaft. Swing the pivot arm assembly to the other output shaft and slide towards drive such that hex locating studs protrude through the pivot arm assembly and secure with two 3/8-24 nuts.

(2) Mount the spline coupling (5) to the drive output shaft using the square key (4) and secure the coupling by tightening the set-screws.

(3) If the generator/alternator has a 16-tooth spline shaft, insert the spline bushing adapter (6) into the splined coupling.

(4) If a 10-inch bolt circle generator/alternator is to be tested, mount this directly to the pivot arm and secure with the 3/8-24 nuts.

(5) If the 5-inch circle generator/alternator is to be tested, mount the adapter flange (3, fig 2-9). Mount the generator/alternator to the adapter flange. Secure with 3/8-24 nuts.

(6) After the above mounting procedures, go to para 2-5 for operation of the test stand.

WARNING

Always remove spline couplings and spline bushings from drive output shafts if not used.

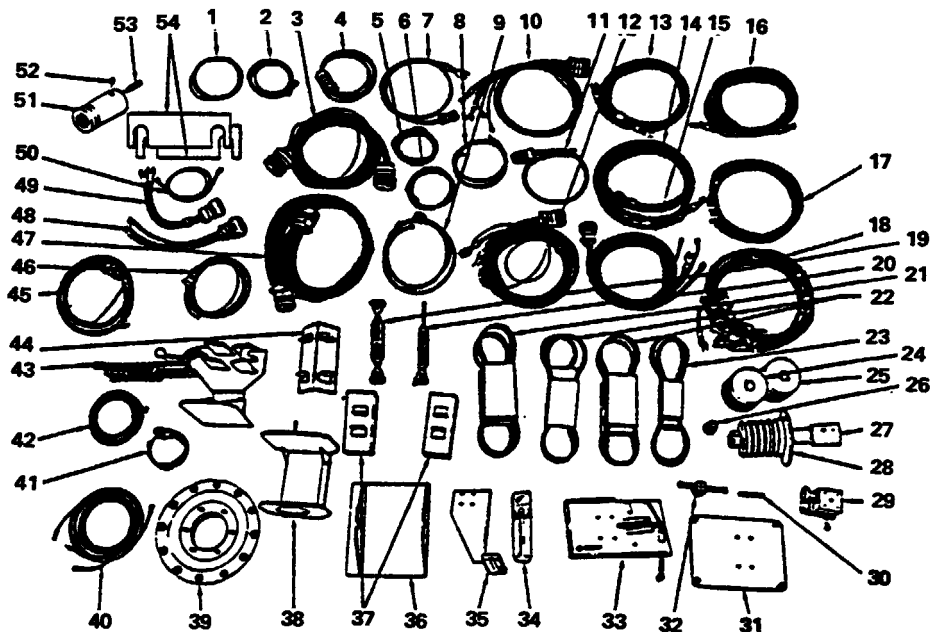

Legend for fig 2-7:

- | | |
|--|--|
| <ul style="list-style-type: none"> 1. Harness, PN 48294 2. Voltmeter Test Lead, PN 48306 3. Harness, PN 48270 4. Harness, PN 48281 5. Harness, PN 48293 6. Harness, PN 48312 7. Harness, PN 48311 8. Harness, PN 48295 9. Harness, PN 48285 10. Harness, PN 48276 11. Harness, PN 48286 12. Harness, PN 48274 13. Harness, PN 48297 14. Harness, PN 48299 15. Harness, PN 48275 16. Harness, PN 48300 17. Harness, PN 48298 18. Harnesses, PN 48305, 48307, 48308 and 48309 19. Turnbuckle Assembly, PN 38454 20. Turnbuckle Assembly Extension, PN 38455 21. V Belts, PN 61195 22. V Belts, PN 61194 23. V Belts, PN 61193 24. Pulley, PN 89337 25. Pulley, PN 89335 26. Adapter, Spline, AN4052-1, PN 11054 27. Pulley Adapter Shaft Assembly, PN 71004 | <ul style="list-style-type: none"> 28. Pulley, PN 89336 29. Multiangle Positioner, PN 302115 30. Square Key, PN SK3202 31. Control Box Mounting Plate, PN SK3145 32. Locking Handle, PN 51057 33. Regulator Mounting Plate Assembly, PN 38555 34. Vibra-tak, PN 31627 35. Regulator Mounting Bracket Assembly, PN 89356 36. Rectifier Mounting Bracket, PN 89352 37. Chain Mounting Assembly, PN 38540 38. Starter Bracket, PN 38346 39. Flange Adapter, PN 11055 40. Voltmeter Test Lead, PN 48306 41. Harness, PN 48287 42. Harness, PN 48301 43. Generator Mounting Bracket Assembly, PN 48318 44. Vise Mounting Assembly, PN 38539 45. Harness, PN 48284 46. Harness, PN 48279 47. Harness, PN 48269 48. Harness, PN 48278 49. Harness, PN 48277 50. Harness, PN 48296 51. Splined Coupling, PN XA584423 52. Set Screw, PN MS51963-64 53. Key, PN MS20066-354 54. Links, PN 69304 |
|--|--|

Figure 2-7. Test stand accessories.

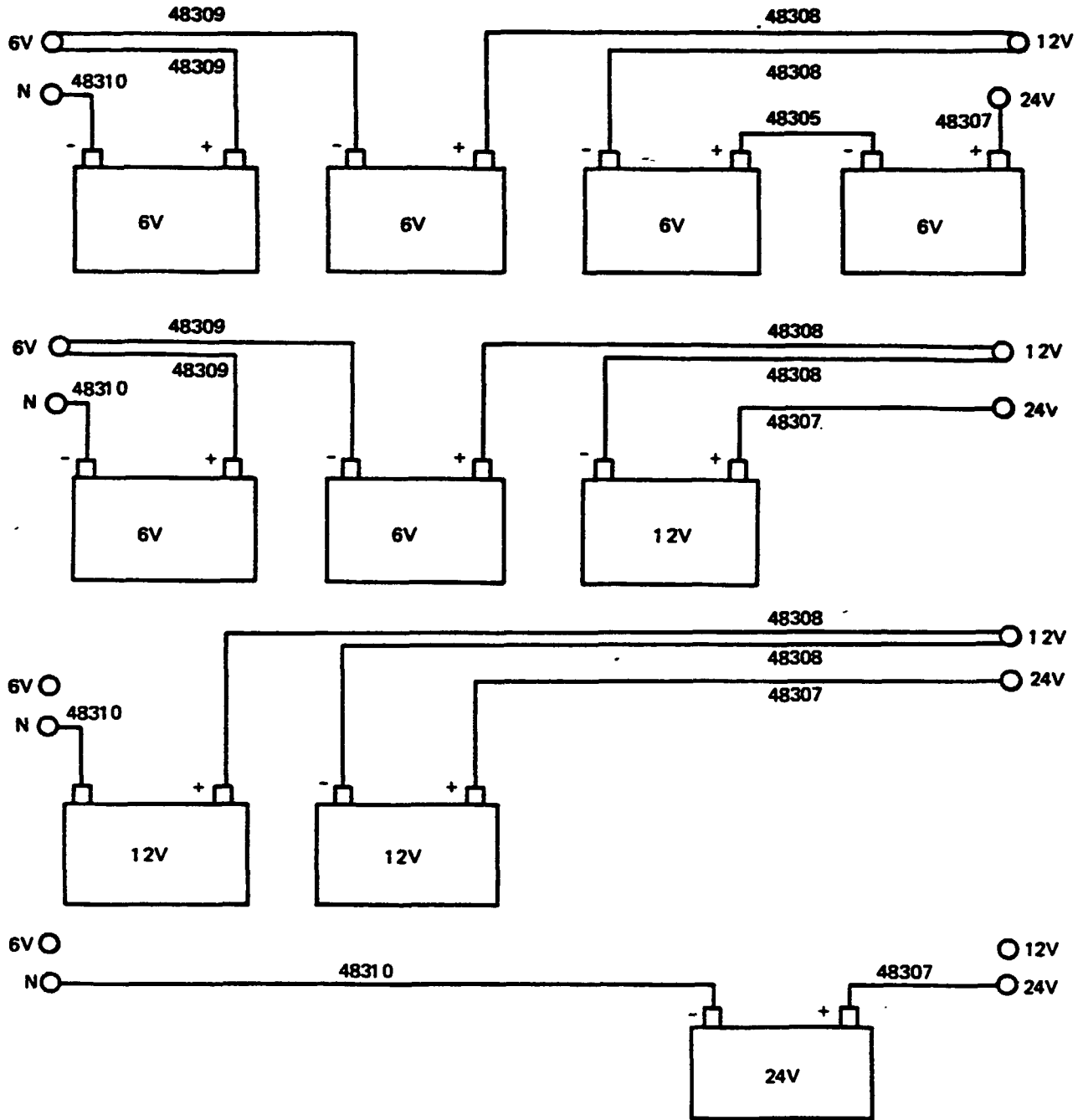

Figure 2-8. Battery connections.

Table 2-1. Initial Control Positions

| Control | Index and Figure No. | Position |
|---|----------------------|---|
| DC AMMETER LOAD & STARTER OUTPUT CURRENT BATTERY CHARGE CURRENT RANGE switch | S14, fig 2-1 | X10 LOAD |
| DC AMMETER LOAD & STARTER OUTPUT CURRENT BATTERY CHARGE CURRENT PRESS FOR BATTERY CHARGE RATE switch | S15, fig 2-1 | OFF |
| DC AMMETER FIELD CURRENT RANGE switch | S30, fig 2-1 | X6 |
| MILLIVOLT METER MILLIVOLT DROP RANGE switch | S16, fig 2-1 | X10 |
| MILLIVOLT METER MILLIVOLT DROP PRESS TO READ switch | S34, fig 2-1 | OFF |
| DC VOLTMETER OUTPUT VOLTAGE RANGE switch | S12, fig 2-1 | X5 |
| DC VOLTMETER OUTPUT VOLTAGE SELECT switch | S11, fig 2-1 | REC-GEN (P/N 7458-2) EXT (P/N 7458-4) |
| TACHOMETER RPM SELECT switch | S36, fig 2-1 | DIRECT DRIVE |
| TACHOMETER RPM PULLEY CALIBRATION control | R35, fig 2-1 | Fully ccw |
| AC AMMETER OUTPUT CURRENT SELECT switch | S25, fig 2-1 | T1 |
| AC AMMETER OUTPUT CURRENT RANGE switch | S26, fig 2-1 | X5 |
| AC VOLTMETER OUTPUT VOLTAGE SELECT switch | S28, fig 2-1 | T1-T2 |
| AC VOLTMETER OUTPUT VOLTAGE RANGE switch | S27, fig 2-1 | X2 |
| EXTERNAL FIELD EXCITER AC SYSTEM switch | S31, fig 2-2 | OFF |

Table 2-1. Initial Control Positions - Continued

| Control | Index and fig no. | Position |
|---|-----------------------------------|----------------------|
| GENERATOR FIELD switch | S37, fig 2-2 | INT GND |
| POLARITY REVERSING switch | S7, fig 2-2 | NEG GND |
| FIELD CIRCUIT switch | S32, fig 2-2 | OFF |
| FINE CONTROL 0-5 AMPS (MAX) switch | S29, fig 2-2 | OFF |
| FIELD CURRENT 0-5 AMPS (MAX) control | R27, fig 2-2 | Fully ccw |
| FIELD CURRENT 0-30 AMPS (MAX) control | R26, fig 2-2 | Fully ccw |
| CIRCUIT BREAKERS | CB2 thru CB9 and CB11, fig 2-2 | In |
| BATTERY CIRCUIT SELECTOR switch | S6, fig 2-2 | OFF (next to 24V) |
| REGULATOR CHECK FIXED RESISTANCE METHOD switch | S13, fig 2-2 | OFF |
| DC VARIABLE VOLTS switch | S10, fig 2-2 | OFF |
| LOAD SELECTION 100 AMPS/50 AMPS switches | S17 thru S19, fig 2-2 | OFF |
| LOAD SELECTION 50 AMPS/25 AMPS switches | S20 thru S22, fig 2-2 | OFF |
| LOAD SELECTION 25 AMPS/12.5 AMPS switches | S23, fig 2-2 | OFF |
| LOAD SELECTION 0-25 AMPS/0-12.5 AMPS switch | S24, fig 2-2 | OFF |
| MASTER LOAD DISCONNECT switch | S8, fig 2-2 | OFF |
| VARIABLE LOAD control | R32, fig 2-2 | Fully ccw |
| VOLTAGE ADJ control | R37, fig 2-2 | Fully ccw |

Table 2-1. Initial Control Positions - Continued

| Control | Index and fig no. | Position |
|---|----------------------|---|
| FIELD SHORTING switch | S38, fig 2-2 | OFF |
| STARTER RHEOSTAT control | R18, fig 2-2 | CW until re- sistance is felt, then back off one full revolu- tion |
| STARTER TEST switch | S9, fig 2-2 | OFF |
| AUX START switch | S39, fig 2-2 | OFF |
| CHARGE TIMER (MINUTES) control | TD1, fig 2-4 | OFF |
| BATTERY CHARGE CIRCUIT control | T3, fig 2-4 | Fully ccw |
| DC VARIABLE POWER SUPPLY 0-32 VDC control | T5, fig 2-4 | Fully ccw |
| Circuit breaker switch | CB1, fig 2-5 | OFF |
| Reversing switch | S1, fig 2-5 | Any |
| AC/DC SYSTEMS EQUALIZER COIL TEST switch | fig 2-3 | OFF |
| AC/DC SYSTEMS IGN SW switch | fig 2-3 | OFF |
| Link between regulator G+ and regulator B+ binding posts | fig 2-3 | OFF |
| Link between regulator G- and regulator B- binding posts | fig 2-3 | OFF |
| D-SENSING switch | fig 2-3 | ON |
| NOTE : Continue with para 2-5. | | |

b. Mounting Pulley Driven Generators/Alternators (fig 2-10).

(1) On part number 7458-4, raise the hinged output shaft guards on the test stand. Position the pivot arm to the drive-output shaft desired, depending upon the speed range of the generator/alternator.

(2) Mount the 10-inch to 5-inch flange adapter (3) onto the pivot arm and secure with 3/8-24 nuts.

(3) Mount the pulley adapter (5) with key (4) onto the drive output shaft and tighten the set screws. Secure the pulley adapter to the flange adapter by use of 3/8-24 nuts.

(4) Mount correct pulley (6) with key (11) on pulley adapter shaft (5) and secure with nut and cotter pin.

(5) Mount the chain mounting assembly (7) loosely with the locking handle (32, fig 2-7) and raise the assembly to its highest point and tighten locking handle.

(6) Mount the generator/alternator in chain vise aligning driven pulley in line with the driver pulley and circumventing the generator/alternator with the chain. It may be necessary to loosen hex nut under vise plate to align pulleys.

(7) Insert pin of chain into chain retaining bracket (7, fig 2-10) and tighten chain.

WARNING

Be certain that chain is clear of all electrical terminals.

CAUTION

On some alternators the shell is of sheet metal and clamping by means of the chain only may cause internal rub and possible damage. Use of vise mounting fixture (44, fig 2-7) or chain mounting fixture (37, fig 2-7) will allow for proper mounting.

(8) Install the pulley belts (8, fig 2-10) onto the driver pulley (6, fig 2-10) and alternator/generator pulley (9, fig 2-10).

(9) Loosen the chain mounting assembly locking handle (32, fig 2-7) and lower obtaining tension on the belts. Tighten locking handle.

(10) After the above mounting procedures go to para 2-5 for operation of the test stand.

c. Mounting of Starters. Starters are mounted by use of the chain mounting assembly (7, fig 2-10) or by use of the starter bracket (38, fig 2-7).

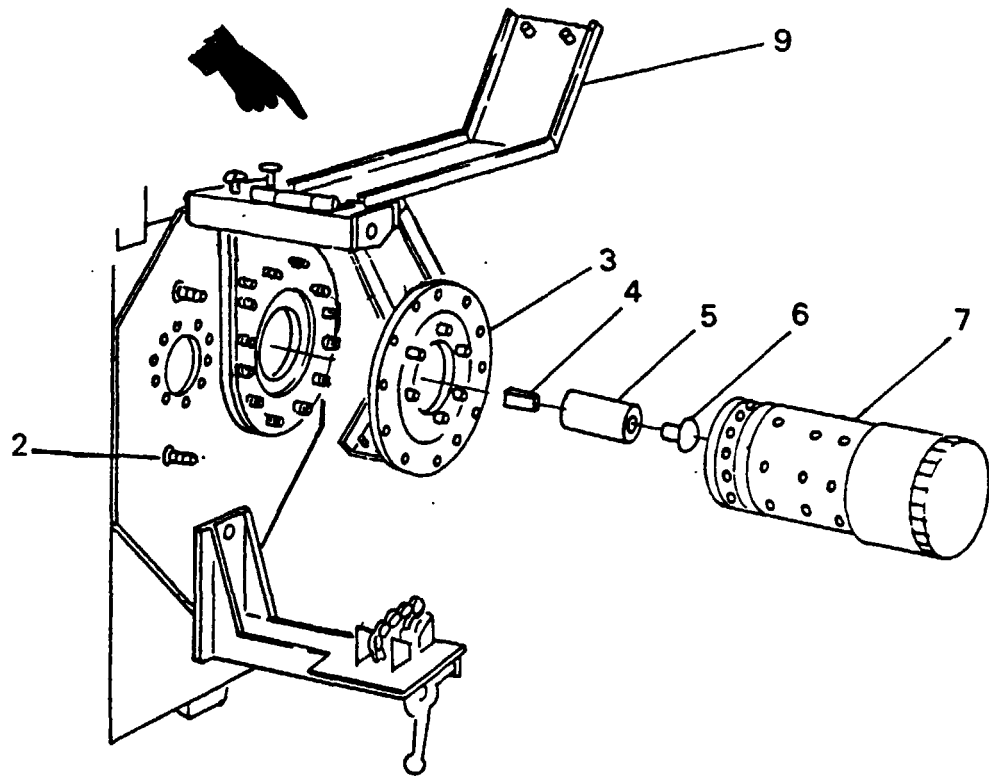

Legend for fig 2-9:

1. Pivot arm
2. Hexagon locating stud
3. Flange adapter, 10-inch B.C. to 5-inch B.C.
4. Square key
5. Spline coupling, 24-teeth internal
6. Adapter, 16 teeth to 24 teeth
7. Direct driven generator
8. Hexagon nuts
9. Belt guard (part number 7458-4 only)

Figure 2-9. Components used for mounting direct driven generators/alternators (typical).

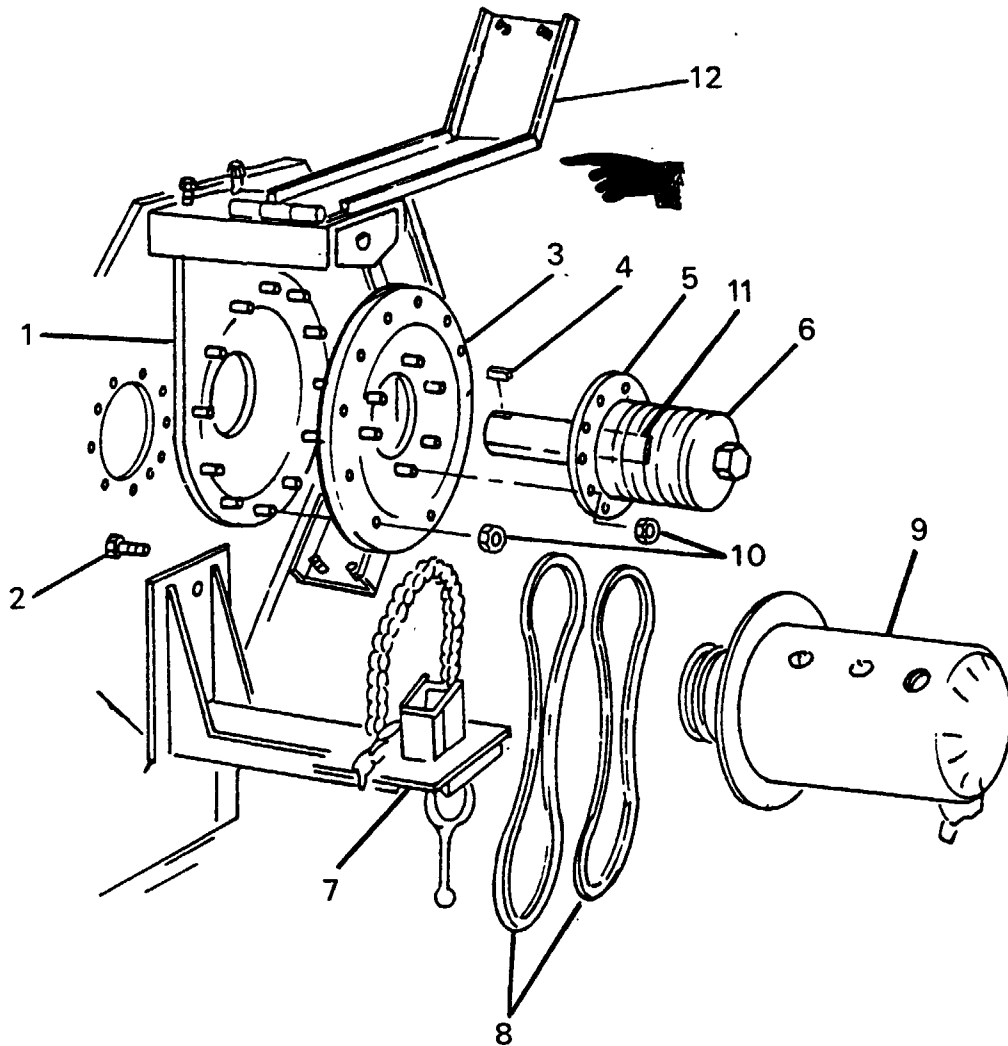

Legend for fig 2-10:

- 1. Pivot arm
- 2. Hex locating stud
- 3. Flange adapter, 10-inch B.C. to 5-inch B.C.
- 4. Square key
- 5. Pulley adapter
- 6. Pulley
- 7. Chain mounting assembly
- 8. Belts
- 9. Component to be tested
- 10. Hex nuts
- 11. Key
- 12. Belt guard (part number 7458-4 only)

Figure 2-10. Components used for mounting pulley driven generators/alternators (typical).

(1) All jaw-type starters with a 5-inch bolt circle are mounted by use of the chain mounting assembly (7, fig 2-10).

(2) All pinion-type starters with SAE mount are mounted by use of the starter mounting bracket (43, fig 2-7).

(3) For starters with lever actuated start switches it will be necessary to mechanically hold the switches in the ON position. Figure 2-11 shows arrangements for activating these lever actuated start switches.

(4) After the above mounting procedures go to para 2-5 for operation of the test stand.

d. Mounting of Rectifiers.

(1) Mount the rectifier assembly onto the rectifier mounting bracket (36-, fig 2-7). Secure with the rectifier nuts.

(2) Install the mounted rectifier into the rectifier chamber (6, fig 4-3) being certain that the rectifier plates are parallel to the flow of cooling air.

(3) After electrical connections are made (fig 2-19), close rectifier chamber (6) door.

(4) After the above mounting procedures go to para 2-5 for operation of the test stand.

e. Mounting Regulators (fig 2-7). All regulators and/or control boxes are mounted onto the voltage regulator mounting bracket (35).

(1) Certain control boxes are mounted onto a control box mounting plate (31) or regulator mounting plate assembly (33) which in turn is mounted onto the multi-angle positioner (29) on the regulator mounting bracket (35).

(2) The regulator mounting bracket (35) is adjustable vertically to allow for ease in testing and may also be swung around the front right corner of the test stand.

(3) It is also possible to adjust the voltage regulator in either of two planes to simulate its actual vehicular mount.

(4) After the above mounting procedures, go to para 2-5 for operation of the test stand.

2-5. GENERAL OPERATION OF TEST STAND. The following paragraphs contain the general operating procedures for the test stand.

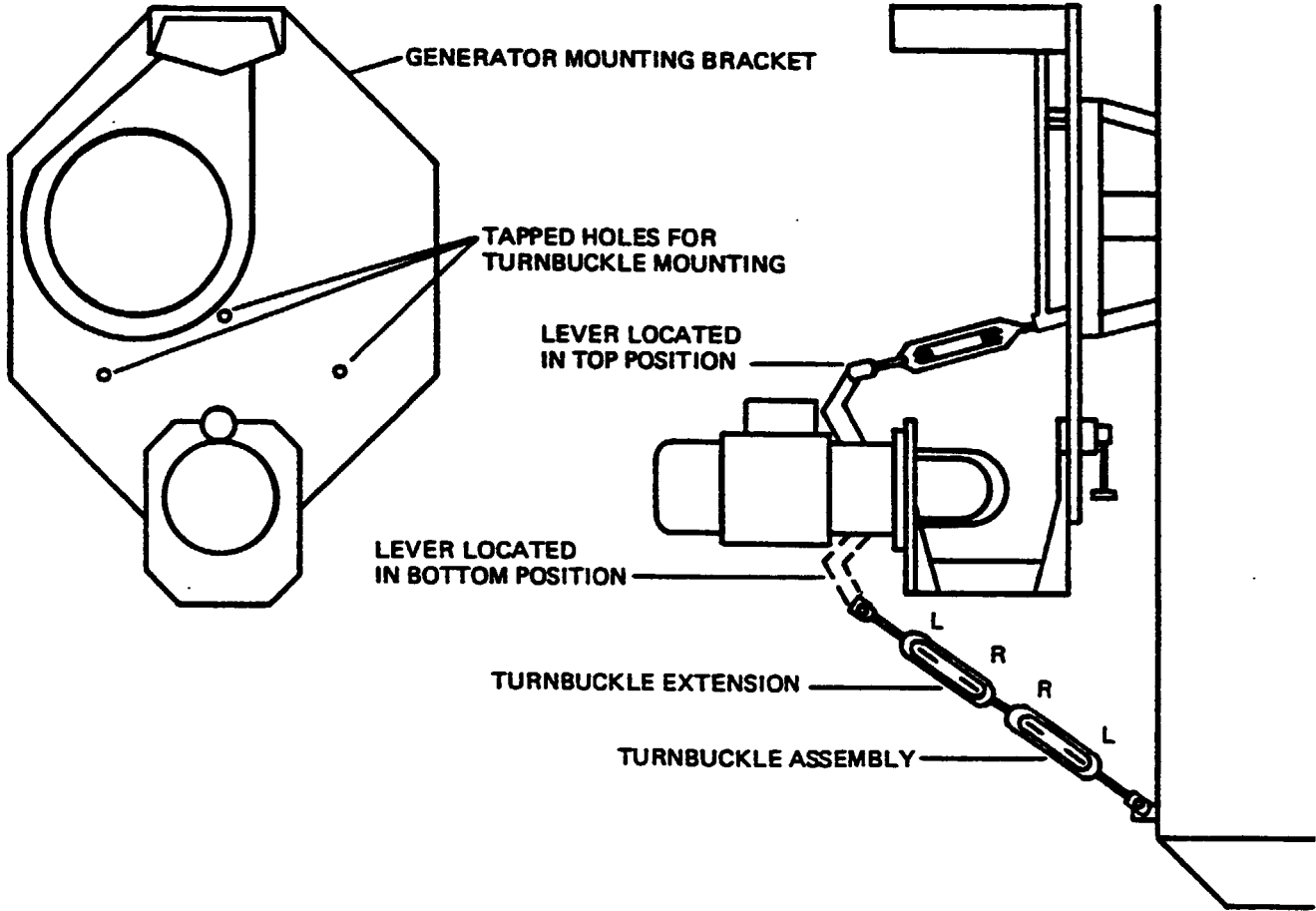

Figure 2-11. Mechanical actuation of lever operated starter start switch.

a. Operation of Test Stand Drive.

WARNING

Use of this equipment involves high voltages. Care must be used to avoid contact with conducting parts. Failure to observe this warning may prove fatal.

WARNING

Use of this equipment involves rotating parts. Be certain that all rotating components are secured. Failure to observe this warning may prove fatal.

CAUTION

Always be certain rotation is correct for equipment being tested to avoid serious damage.

NOTE

For hookup of a system under test refer to its pertinent step and figure per the index.

(1) Position all switches and controls as specified in table 2-1.

(2) Open the high voltage compartment door (5, fig 4-3) and position reversing switch (S1, fig 2-5) to the UP position for counterclockwise rotation or to the DOWN position for clockwise rotation as determined by the rotation of the equipment to be mounted.

(3) Position circuit breaker switch (CB1, fig 2-5) to the ON position.

(4) Close the high voltage compartment door (5, fig 4-3).

(5) Press START pushbutton switch (S3, fig 2-4) and hold for not more than 30 seconds to allow time for the load bank airflow switch to activate and keep the starter energized.

CAUTION

Repeated starting at frequent short intervals may damage the drive magnetic starter coil (MS1, fig 2-5). This coil is rated at 57 volts ac to allow start closure without chatter when starting from a power source which drops sharply upon application of initial motor load.

(6) Vary SPEED CONTROL (fig 2-4) to obtain the desired speed as indicated by TACHOMETER RPM meter (M1, fig 2-1). Counterclockwise rotation of the SPEED CONTROL (fig 2-4) increases speed and clockwise rotation decreases speed.

(7) To stop the varidrive, set SPEED CONTROL (fig 2-4) fully clockwise to minimum speed and press STOP pushbutton switch (S2, fig 2-4).

(8) Open the high voltage compartment door and position circuit breaker switch (CB1, fig 2-5) to the OFF position.

NOTE

If varidrive is not to be used often and is to be idle for a week or so, position SPEED CONTROL (fig 2-4) to mid speed range before stopping. This will preclude a varidrive belt set at a small radius which will give a thumping sound when started again until the belt becomes flexible.

b. Operating TACHOMETER RPM Meter. The tachometer indicator circuitry is so designed that the speed of the generator being tested, whether it be direct driven or pulley driven, is indicated on TACHOMETER RPM meter (M1, fig 2-1).

(1) Direct Drive Generators.

(a) Set the TACHOMETER RPM SELECT switch (S36, fig 2-1) to the DIRECT DRIVE position.

(b) TACHOMETER RPM meter (M1, fig 2-1) will now indicate directly the speed of both output shafts.

1. The low speed output shaft (1, fig 1-2), right side facing drive take-off, will indicate on the 0-5100 RPM range.

2. The high speed output shaft (3, fig 1-2), left side facing drive take-off, will indicate on the 0-12000 RPM range.

(2) Pulley Driven Generators - When testing pulley-driven generators, it will be necessary to establish a speed for the generator and adjust the tachometer indicator to indicate this speed. After completing this adjustment, any variation in the speed of the pulley-driven generator will be indicated on the tachometer indicator. To make this adjustment properly, proceed as follows:

(a) Mount the generator to be tested on the varidrive (fig 2-9 and 2-10).

(b) Turn TACHOMETER RPM SELECT switch (S36, fig 2-1) to the DIRECT DRIVE position.

(c) Determine the speed of the driven generator by using the following formula:

$$N = \frac{4(N \text{ DRIVER})}{\text{DIA DRIVEN}}$$

Where N = Speed

4 = Diameter of driver pulley on test stand

For example:

Have the drive pulley mounted on the low speed shaft of the varidrive. When the diameter of the driven generator pulley is 5 inches, proceed as follows:

1. Set TACHOMETER RPM SELECT switch (S36, fig 2-1) to DIRECT DRIVE position.

2. Set the speed of the drive motor to 3000 revolutions per minute on the 0-5100 scale.

3. The speed of the driven generator pulley = $\frac{4(3000)}{5}$ or 2400 revolutions per minute.

4. Set TACHOMETER RPM SELECT switch (S36, fig 2-1) to the CAL PULLEY position.

5. Adjust TACHOMETER RPM meter (M1, fig 2-1) to read 2400 revolutions per minute on the 0-5100 scale, using TACHOMETER RPM PULLEY CALIBRATION control (R35, fig 2-1). Any variation in the speed of the driven generator will now be indicated directly on TACHOMETER RPM meter (M1, fig 2-1).

(d) Start the test stand (para 2-5a(5)) and adjust the speed of the drive motor using SPEED CONTROL (fig 2-4) to some cardinal point on the indicator scale, depending upon which output shaft is being used.

(e) Turn TACHOMETER RPM SELECT switch (S36, fig 2-1) to the CAL PULLEY position.

(f) Rotate TACHOMETER RPM PULLEY CALIBRATION control (R35, fig 2-1) until TACHOMETER RPM meter (M1, fig 2-1) shows the speed determined in (c) above. This speed may be set on either scale. Stop the varidrive.

c. Polarity Reversing Switch.

(1) REVERSING switch (S7, fig 2-2) is used to establish the grounding for the specific system undergoing test. The generating system may be either negative ground or positive ground.

(2) Prior to starting any testing, this REVERSING switch must be positioned for either NEG-GND or POS-GND, depending upon the generator system being tested.

2-6. SPECIFIC MODES OF OPERATION. The following paragraphs contain the instructions to operate the test stand in the various modes of operation. Figure 2-12 through 2-15 illustrate various typical test setups.

2-7. TESTING INTERNAL GROUND FIELD AND EXTERNAL GROUND FIELD GENERATORS. Either standard duty voltage regulators or heavy duty voltage regulators may be used for control of automotive generators. The main difference between the two systems is the method of generator field control. In a standard duty voltage regulator, the generator field is externally grounded, whereas in a heavy duty voltage regulator, the generator field is internally grounded. When using FIELD CURRENT 0-30 AMPS (MAX) control (R26, fig 2-2) to control the voltage output of a generator being tested without a voltage regulator, GENERATOR FIELD switch (S37) must be set to either the EXT GND or the INT GND position, as determined by the type of system undergoing test. When testing a generator with a voltage regulator in the system, the regulator itself will complete the field circuit.

NOTE

Attach leads from the generator to the test stand in the same manner for either type of generator.

2-8. TESTING VOLTAGE REGULATORS

CAUTION

Removal or installation of an electrical jumper or connecting cable will be accomplished only when that circuit is not being supplied with electrical power unless specified in test.

Load resistors of 1/4 OHM, 1 1/2 OHMS, 2 1/4 OHMS, and 7 OHMS (below S13, fig 2-2) are provided in the test stand for the fixed resistance method of checking-and adjusting voltage regulators. The appropriate fixed resistance is substituted for the external charging circuit. Proceed as follows:

- a. Disconnect the battery lead at the regulator.
- b. Connect a lead between the regulator BAT terminal and 1/4 OHM, 1 1/2 OHM, 2 1/4 OHM, or 7 OHM binding post (below S13, fig 2-2), as applicable. When REGULATOR CHECK FIXED RESISTANCE METHOD switch (S13, fig 2-2) is set to the ON position, the selected fixed resistance is connected between the regulator BAT terminal and the negative bus circuit or ground. Normally, use the 1 1/2 ohm resistance with 12

volt units, and the 7 ohm resistance with 24 volt units. However, with 6 volt units of less than 15 amperes capacity, some specifications will call for the use of 1 1/2 ohms fixed resistance in order to avoid interference with the current regulator, and with 12 volt regulators of less than 15 amperes capacity, the use of 2 1/4 ohms may be specified for the same reason. The 1/4 ohm resistance is used for certain 6 and 12 volt systems, but it is connected to the positive bus.

2-9. OPERATING AND TEST INSTRUCTIONS. Operating and test instructions in the remaining paragraphs of this section provide the operator with general test procedures for items that can be checked and tested using the test stand. (Refer to table 2-1.1.) Each item must be thoroughly bench inspected, adjusted, and tested before attempting to test the item on the test stand. Always refer to the latest pertinent technical manual and/or technical bulletin for the item, as publications will contain the latest rebuild procedures, settings, adjustments, and test procedures. To obtain a more accurate setting and adjustment, items should be reset and readjusted several times, and a test made after each setting and adjustment.

Table 2-1.1 Items That May Be Tested

| Item | Manufacturer | Manufacturer's part no. | Army part no. | Test setup fig. no. |
|------------|---------------|-------------------------|---------------|---------------------|
| Generator | Lear-Siegler | G-22-6F-0 | 10889713 | 2-16 |
| Generator | Lear-Siegler | G-22-9 | 10914831 | 2-17 |
| Generator | Lear-Siegler | G-22-7F-0 | 10889998 | 2-16 |
| Generator | Prestolite | GHA-4804UT | 10950808-1 | 2-18 |
| Rectifier | Leece Neville | 1106CA | 10906314 | 2-19 |
| Rectifier | Leece Neville | C0011110CA | 11640182 | 2-19 |
| Rectifier | Leece Neville | 1029CP | 7954343 | 2-19 |
| Regulator | Delco Remy | 1118424 | 7351952 | 2-20 |
| Regulator | Delco Remy | 1118656 | 8360020 | 2-20 |
| Regulator | Vapor | 26440001-05 | 10947439 | 2-21 |
| Regulator | Vapor | 26540208-03 | 11621812 | 2-22 |
| Regulator | Vapor | 26640473-04 | 11631857 | 2-20 |
| Regulator | Prestolite | PR-VBC-4004UT | 8712283 | 2-20 |
| Regulator | Leece Neville | 91040(5073RB) | 11640367 | 2-21 |
| Alternator | Prestolite | AMA-5103UT | 10929868 | 2-23 |
| Alternator | Leece Neville | A0015258GS | 7954722 | 2-25 |
| Alternator | Leece Neville | A0015320GP | 8336691 | 2-25 |
| Alternator | Leece Neville | A001-3018-AB | 11613630 | 2-24 |
| Alternator | Leece Neville | A001-2184-AC | 10947517 | 2-26 |
| Alternator | Leece Neville | A001-2152-AC | 10947517 | 2-26 |
| Alternator | Leece Neville | A0015516AA | 1164980 | 2-25 |
| Alternator | Leece Neville | A0015504AB | 10922191 | 2-25 |
| Starter | Bendix | EC-3615-1 | 7386254 | 2-27 |
| Starter | Bendix | EC-1416-29F | 7539438 | 2-27 |
| Starter | Delco Remy | 1108898 | 7389561 | 2-28 |

Table 2-1.1 Items That May Be Tested (cont)

| Item | Manufacturer | Manufacturer's part no. | Army part no. | Test setup fig. no. |
|---------|---------------|-------------------------|---------------|---------------------|
| Starter | Delco Remy | 1113944 | 7402334 | 2-28 |
| Starter | Delco Remy | 1109972 | 7731426 | 2-28 |
| Starter | Delco Remy | 1108575 | 7762618 | 2-28 |
| Starter | Delco Remy | 1108259 | 8737705 | 2-28 |
| Starter | Delco Remy | 1113943 | 10911018 | 2-28 |
| Starter | Delco Remy | 1113940 | 10947131 | 2-28 |
| Starter | Delco Remy | 1109045 | - | 2-29 |
| Starter | Delco Remy | 1113847 | - | 2-28 |
| Starter | Lear Siegler | 20074-000 | 7998649 | 2-27 |
| Starter | Prestolite | MCZ-4111T | 10943753 | 2-28 |
| Starter | Prestolite | MDZ-4001UT | 10945002 | 2-29 |
| Starter | Prestolite | MBD-4044UT | 10951134 | 2-29 |
| Starter | Prestolite | MFY-6101-1UT | 10951385-1 | 2-28 |
| Starter | Prestolite | MFY6101-KUT | 10951385-2 | 2-28 |
| Starter | Prestolite | AL-MCZ-4002-UT | 7355783 | 2-29 |
| Starter | Prestolite | AL-MEK-6001-AT | 8712479 | 2-28 |
| Starter | Prestolite | MDZ-4001-UT | 10945002 | 2-29 |
| Starter | Lear Siegler | D42-1-0 | 7018076 | 2-27 |
| Starter | Leece Neville | 7072MC | 10935376 | 2-28 |

a. Testing DC Generators (Without Regulators). (Refer to fig 2-16, 2-17, and 2-18.)

WARNING

The noise level is high during operation of the test stand. Wear an acoustical earmuff for protection. (An acoustical earmuff is provided as an accessory with part number 7458-4.)

NOTE

This test procedure is only a typical procedure.

- (1) Position test stand controls in accordance with table 2-1.
- (2) Connect generator output to test stand GENERATOR binding posts (fig 2-16, 2-17, and 2-18).

NOTE

When testing dc generators without a regulator, it will be necessary to control generator output voltage with the FIELD CURRENT controls (R26 and R27, fig 2-2) on the test stand. Refer to fig 2-16 for link position.

(3) Bolt test lead to generator frame to ground generator to test stand ground.

(4) Set DC AMMETER LOAD & STARTER OUTPUT CURRENT BATTERY CHARGE CURRENT RANGE switch (S14, fig 2-1) to the proper setting as governed by current rating of generator.

(5) Set GEN FIELD switch (S37, fig 2-2) to proper position for generator undergoing test.

(6) Set DC AMMETER FIELD CURRENT RANGE switch (S30, fig 2-1) to proper setting for generator undergoing test.

(7) Set DC VOLTMETER OUTPUT VOLTAGE SELECT switch (S11, fig 2-1) to RECT GEN position.

(8) Set FINE CONTROL 0-5 AMPS (MAX) switch (S29, fig 2-2) to ON or OFF position, depending upon system being tested. ON position is generally used only for testing transport fleet (automotive type) generators.

NOTE

FIELD CURRENT 0-5 AMPS (MAX) control (R27, fig 2-2) is rated at 5 amperes; therefore, DC AMMETER FIELD CURRENT meter (M7, fig 2-1) should be observed carefully and this control should not be used when field current exceeds 5 amperes. FIELD CURRENT 0-30 AMPS (MAX) control (R26, fig 2-2) is used alone when testing combat fleet (aircraft) type generators, which normally employ a carbon pile or solid state type regulator.

(9) Open high voltage compartment access door (5, fig 4-3) on left side of test stand and set circuit breaker switch (CB1, fig 2-5) to ON. Be certain to close access door or interlock (S4, fig 2-5) may keep control circuit open.

(10) Start varidrive by pressing START pushbutton switch (S3, fig 2-4) and maintaining pressure for not more than 30 seconds.

(11) Adjust varidrive speed with SPEED CONTROL (fig 2-4) until desired generator speed is indicated on TACHOMETER RPM meter (M1, fig 2-1).

(12) Set FIELD CIRCUIT switch (S32, fig 2-2) to MANUAL position. Increase generator field current by rotating FIELD CURRENT 0-5 AMPS (MAX) control (R27) or FIELD CURRENT 0-30 AMPS (MAX) control (R26), as applicable, clockwise until proper generator voltage is indicated on DC VOLTMETER OUTPUT VOLTAGE meter (M2, fig 2-1).

NOTE

Generator voltage will drop off with application of load. It will be necessary to adjust generator field current by use of FIELD CURRENT 0-5 AMPS (MAX) control (R27, fig 2-2) or FIELD CURRENT 0-30 AMPS (MAX) control (R26).

(13) Set MASTER LOAD DISCONNECT switch (S8, fig 2-2) to ON.

(14) Select desired load by use of LOAD SELECTION switches (S17 through S24, fig 2-2).

TM 9-4910-663-12

(15) Set DC AMMETER LOAD & STARTER OUTPUT CURRENT BATTERY CHARGE CURRENT RANGE switch (S14, fig 2-1) to appropriate position and observe load current on DC AMMETER LOAD & STARTER OUTPUT CURRENT BATTERY CHARGE CURRENT meter (M3, fig 2-1).

(16) Set DC AMMETER FIELD CURRENT switch (S30, fig 2-1) to appropriate position and observe generator field current on DC AMMETER FIELD CURRENT meter (M7, fig 2-1).

(17) Control generator speed by using SPEED CONTROL (fig 2-4).

NOTE

FIELD CURRENT 0-30 AMPS (MAX) control (R26, fig 2-2) must be adjusted while varying speed because generator voltage will vary proportionately with speed.

(18) Perform required generator tests as specified in test procedures of manufacturer.

(19) Upon completion of tests, decrease generator output voltage by adjusting FIELD CURRENT 0-30 AMPS (MAX) control (R26, fig 2-2) and 0-5 AMPS (MAX) control (R27, fig 2-2) counterclockwise. Then, decrease loading by setting LOAD SELECTION switches (S17 through S24) to OFF. Place MASTER LOAD DISCONNECT switch (S8) to OFF position. Reduce varidrive speed to one quarter speed using SPEED CONTROL (fig 2-4).

(20) Set all switches to OFF and press STOP pushbutton switch (S2, fig 2-4).

(21) If no further testing is to be performed on the test stand, set circuit breaker switch (CBL, fig 2-5) to OFF.

b. Testing Generator-Regulator (Negative Ground). (Refer to fig 2-11, 2-16, 2-17, 2-18, 2-20, 2-21, and 2-22.)

NOTE

This test procedure is only a typical procedure.

(1) Position test stand controls in accordance with table 2-1.

(2) Install regulator on regulator mounting bracket (33, 34, fig 2-7) and adjust to desired position.

(3) Install batteries in battery compartment (4, fig 4-3) of test stand and connect to proper binding posts (refer to para 2-3h and fig 2-8). Four binding posts, labelled -, 6V, 12V, and 24V, are provided on terminal board assembly in battery compartment.

(4) Set BATTERY CIRCUIT SELECTOR switch (S6, fig 2-2) to proper voltage for system under test.

(5) Set DC VOLTMETER OUTPUT VOLTAGE SELECT switch (S11, fig 2-1) to BAT, set MASTER LOAD DISCONNECT switch (S8, fig 2-2) to ON, and make sure that system voltage to be tested is same as battery voltage. Set MASTER LOAD DISCONNECT switch (S8) to OFF position, then, set BATTERY CIRCUIT SELECTOR switch (S6) to OFF and set DC VOLTMETER OUTPUT VOLTAGE SELECT switch (S11, fig 2-1) to RECT GEN position.

(6) Connect regulator armature to REGULATOR G+ binding post (fig 2-3), regulator field to REGULATOR F-B binding post, and regulator battery to REGULATOR B+ binding post. Where a BAT- and GEN- are required, connect these respectively to REGULATOR B-binding post and REGULATOR G- binding post.

(7) Using test leads, connect generator output to GENERATOR G+, GENERATOR G-, and GENERATOR F binding posts (fig 2-3).

(8) Using test lead, connect ground lead from regulator case to REGULATOR GND binding post (fig 2-3).

(9) Set POLARITY REVERSING switch (S7, fig 2-2) to NEG GND and GEN FIELD switch (S37, fig 2-2) to EXT GND or INT GND, as required for the generator undergoing test.

(10) Remove link between REGULATOR B+ binding post (fig 2-3) and REGULATOR G+ binding post. Refer to fig 2-12 for link position.

(11) Verify that FINE CONTROL 0-5 AMPS (MAX) switch (S29, fig 2-2) is set to OFF.

(12) Set FIELD CIRCUIT switch (S32, fig 2-2) to REGULATOR position.

(13) Open high voltage compartment access door and set reversing switch (S1, fig 2-5) to position that produces proper direction of rotation for unit undergoing test. Set circuit breaker switch (CB1) to ON, and close high voltage compartment.

(14) Start varidrive by pressing START pushbutton switch (S3, fig 2-4) and hold for no more than 30 seconds.

CAUTION

Observe DC VOLTMETER OUTPUT VOLTAGE meter (M2, fig 2-1) and TACHOMETER RPM meter (M1, fig 2-1) as generator comes up to speed. Do not exceed voltage or speed limits of generator being tested.

(15) Using SPEED CONTROL (fig 2-4), vary drive speed throughout speed range of generator, observing regulated voltage (M2, fig 2-1) and TACHOMETER RPM meters (M1).

(16) Set DC VOLTMETER OUTPUT VOLTAGE RANGE switch (S12, fig 2-1) to proper voltage for system under test.

(17) Set DC AMMETER LOAD & STARTER OUTPUT CURRENT BATTERY CHARGE CURRENT RANGE switch (S14, fig 2-1) and DC AMMETER FIELD CURRENT RANGE switch (S30) to proper positions for current ratings of generator.

(18) Set speed (fig 2-4 and M1, fig 2-1) at minimum rated generator speed, and set MASTER LOAD DISCONNECT switch (S8, fig 2-2) to ON.

(19) Using LOAD SELECTION switches (S17 through S24, fig 2-2) and VARIABLE LOAD control (R32), as applicable, increase load on generator until rated load is reached, and vary generator speed throughout speed range.

(20) Shock test generator and regulator, using MASTER LOAD DISCONNECT switch (S8, fig 2-2), noting regulated voltage. Set switch to OFF, then to ON to shock load.

(21) Increase loading slowly and observe slight drop off in regulated voltage and leveling off of current reading when current limiter comes into play.

(22) Decrease load to zero by setting LOAD SELECTION switches (S17 through S24, fig 2-2) to OFF, and set MASTER LOAD DISCONNECT switch (S8, fig 2-2) to OFF.

(23) Set BATTERY CIRCUIT SELECTOR switch (S6, fig 2-2) to OFF.

(24) When required by equipment manufacturer's test procedure, perform differential voltage and reverse current tests as follows:

(a) Set FIELD CIRCUIT switch (S32, fig 2-2) to MANUAL position and adjust generator voltage to within 2 to 4 volts of battery voltage by rotating FIELD CURRENT 0-30 AMPS (MAX) control (R26) clockwise. Then, set BATTERY CIRCUIT SELECTOR switch (S6) and MASTER LOAD DISCONNECT switch (S8) to ON.

(b) Select appropriate setting of MILLIVOLT METER MILLIVOLT DROP RANGE switch (S16, fig 2-1), and press MILLIVOLT METER MILLIVOLT DROP PRESS TO READ switch (S34).

(c) Increase generator voltage very slowly while observing MILLIVOLT METER MILLIVOLT DROP meter (M4, fig 2-1). Voltage should increase and then decrease to zero when cut-off relay closes. Highest voltage attained is the differential voltage. Release MILLIVOLT METER MILLIVOLT DROP PRESS TO READ switch (S34).

(d) Decrease generator voltage very slowly while observing DC AMMETER LOAD & STARTER OUTPUT CURRENT BATTERY CHARGE CURRENT meter (M3, fig 2-1). Current should decrease, then indicate a reverse reading, then come back to zero when reverse current cut-out relay opens. Maximum reverse current attained is reverse current reading for partitular regulator under test.

- (e) Set BATTERY CIRCUIT SELECTOR switch (S6, fig 2-2) to OFF.
- (f) Set FIELD CIRCUIT switch (S32, fig 2-2) to REGULATOR position. This will give regulated voltage, provided regulator has been properly adjusted.
- (g) Set MILLIVOLT METER MILLIVOLT DROP RANGE switch (S16, fig 2-1) to X1 position.
- (h) Apply specified load to generator, press MILLIVOLT METER MILLIVOLT DROP PRESS TO READ switch S34, fig 2-1) and note millivolt drop across contacts for a given load. (Refer to equipment manufacturer's test procedure.)
- (i) Perform other tests required by manufacturer's specifications.
- (j) Upon completion of tests, set MASTER LOAD DISCONNECT switch (S8, fig 2-2) to OFF.
- (k) Set FIELD CIRCUIT switch (S32, fig 2-2) to OFF.
- (25) Reduce varidrive speed to one-quarter speed by turning SPEED CONTROL (fig 2-4) clockwise, and stop varidrive by pressing STOP pushbutton switch (S2).

c. Testing Generator-Regulator (Positive Ground). (Refer to fig 2-12, 2-16, 2-17, 2-18, 2-20, 2-21, and 2-22.)

NOTE

This test procedure is only a typical procedure.

- (1) Position test stand controls in accordance with table 2-1.
- (2) Install regulator on regulator mounting bracket located on the right hand corner of test stand, and adjust to desired position.
- (3) Install batteries in battery compartment (4, fig 4-3) of test stand, and connect to proper binding posts on terminal board assembly in battery compartment (refer to para 2-3 and fig 2-8).
- (4) Set BATTERY CIRCUIT SELECTOR switch (S6, fig 2-2) to the proper voltage for system under test.
- (5) Set DC VOLTMETER OUTPUT VOLTAGE SELECT switch (S11, fig 2-1) to BAT. Set MASTER LOAD DISCONNECT switch (S8, fig 2-2) to ON position. Make certain that battery voltage is same as volts e of system under test. Then, set BATTERY CIRCUIT SELECTOR switch (S6) to OFF, and set DC VOLTMETER OUTPUT VOLTAGE SELECT switch (S11, fig 2-1) to RECT GEN position. Place MASTER LOAD DISCONNECT switch (S8, fig 2-2) to OFF position.

(6) Using test leads, connect generator output to GENERATOR G+, GENERATOR G-, and GENERATOR F binding posts (fig 2-3).

(7) Connect regulator armature to REGULATOR G+ binding post (fig 2-3), regulator field to REGULATOR F-B binding post, and regulator battery to REGULATOR B+ binding post. Where a BAT- and a GEN- are required, connect these respectively to REGULATOR B- binding post and REGULATOR G- binding post.

(8) Using test lead, connect ground lead from regulator case to REGULATOR GND binding post (fig 2-3).

(9) Set POLARITY REVERSING switch (S7, fig 2-2) to POS GND position, and GENERATOR FIELD switch (S37, fig 2-2) to EXT GND or INT GND position, as appropriate for system under test.

(10) Remove link between REGULATOR G+ binding post (fig 2-3) and REGULATOR B+ binding post.

(11) Verify that FINE CONTROL 0-5 AMPS (MAX) switch (S29, fig 2-2) is set to OFF.

(12) Set FIELD CIRCUIT switch (S32, fig 2-2) to REGULATOR position.

(13) Open high voltage compartment access door (5, fig 4-3) and set reversing switch (S1, fig 2-5) to position required to product proper direction of rotation of generator. Set circuit breaker switch (CB1) to ON, and close high voltage compartment access door.

(14) Start varidrive by pressing START pushbutton switch (S3, fig 2-4) for no more than 30 seconds.

(15) Note generator output voltage (M2, fig 2-1) as generator comes up to speed.

(16) Vary speed throughout speed range of generator by using SPEED CONTROL (fig 2-4) while observing DC VOLTMETER OUTPUT VOLTAGE meter (M2, fig 2-1) and TACHOMETER RPM meter M1

(17) Set DC VOLTMETER OUTPUT VOLTAGE RANGE switch (S12, fig 2-1) to proper voltage setting for system under test.

(18) Set DC AMMETER LOAD & STARTER OUTPUT CURRENT BATTERY CHARGE CURRENT RANGE switch (S14, fig 2-1) and DC AMMETER FIELD CURRENT RANGE switch (S30) to proper positions for current rating of generator.

(19) Set speed at minimum rated generator speed.

(20) Set MASTER LOAD DISCONNECT switch (S8, fig 2-2) to ON.

(21) Using LOAD SELECTION switches (S17 through S24, fig 2-2) and VARIABLE LOAD control (R32), as applicable, increase load on

generator gradually until rated load is reached, and vary generator speed throughout generator speed range while observing DC VOLTMETER OUTPUT VOLTAGE meter (M2, fig 2-1) and TACHOMETER RPM meter M1

(22) Using MASTER LOAD DISCONNECT switch (S8, fig 2-2) shock test generator and regulator while noting regulated voltage. Set MASTER LOAD DISCONNECT switch to OFF, then to ON to shock load.

(23) Increase loading slowly and observe drop off in voltage indicated on DC VOLTMETER OUTPUT VOLTAGE meter (M2, fig 2-1) when current limiter comes into play. Also note lack of current increase with increasing load.

(24) Decrease load to zero by setting all LOAD SELECTION switches (S17 through S24, fig 2-2) to OFF and set MASTER LOAD DISCONNECT switch (S8) to OFF.

(25) Set BATTERY CIRCUIT SELECTOR switch (S6, fig 2-2) to OFF.

(26) When required by manufacturer's test procedure, perform differential voltage and reverse current tests as follows:

(a) Set FIELD CIRCUIT switch (S32, fig 2-2) to MANUAL position and adjust generator voltage on DC VOLTMETER OUTPUT VOLTAGE meter (M2, fig 2-1) to within 2 to 4 volts of battery voltage by rotating FIELD CURRENT 0-30 AMPS (MAX) control (R26, fig 2-2) in clockwise direction. Then set BATTERY CIRCUIT SELECTOR switch (S6) and MASTER LOAD DISCONNECT switch (S8) to ON position.

(b) Press and hold MILLIVOLT METER MILLIVOLT DROP PRESS TO READ switch (S34, fig 2-1). Increase generator voltage very slowly, using FIELD CURRENT 0-30 AMPS (MAX) control (R26, fig 2-2), while observing MILLIVOLT METER MILLIVOLT DROP meter (M4, fig 2-1). Voltage should increase and then decrease to zero when cutout relay closes. Highest voltage attained is differential voltage. Release MILLIVOLT METER MILLIVOLT DROP PRESS TO READ switch (S34).

(c) Slowly decrease generator voltage with FIELD CURRENT 0-30 AMPS (MAX) control (R26, fig 2-2) while observing DC AMMETER LOAD & STARTER OUTPUT CURRENT BATTERY CHARGE CURRENT meter (M3, fig 2-1). Current should decrease, then indicate a reverse reading, and then come back to zero when cut-out relay opens. Maximum reverse current attained is reverse current reading for particular generator under test.

(d) Set BATTERY CIRCUIT SELECTOR switch (S6, fig 2-2) to OFF.

(e) Set FIELD CIRCUIT switch (S32, fig 2-2) to REGULAR position. This will give regulated voltage, controlled by regulator.

(f) Set MILLIVOLT METER MILLIVOLT DROP RANGE switch (S16, fig 2-1) to X1 position.

(g) Apply specified load to generator, press MILLIVOLT METER MILLIVOLT DROP PRESS TO READ switch (S34, fig 2-1), and note millivolt drop across contacts for a given load. (Refer to manufacturer's test specifications and procedures.)

(h) Perform other tests required by manufacturer's specifications.

(i) Upon completion of tests, set MASTER LOAD DISCONNECT switch (S8, fig 2-2) and FIELD CIRCUIT switch (S32) to OFF.

(27) Reduce varidrive speed to one-quarter speed by turning SPEED CONTROL (fig 2-4) clockwise, and stop varidrive by pressing STOP pushbutton switch (S2).

d. Testing AC/DC Systems (28 Volts, 100 to 400 Amperes, Externally Rectified). (Refer to fig 2-13.)

WARNING

When performing tests on AC/DC systems with external selenium type rectifiers, be cautious not to apply overvoltage as this will cause a rectifier breakdown producing a selenium dioxide gas which may be toxic if inhaled for a period of time. If a disagreeable odor such as hydrogen sulfide is detected, shut down test stand and ventilate area. Always disconnect rectifier from test stand upon completion of tests.

NOTE

This test procedure is a typical procedure.

(1) Position test stand controls in accordance with table 2-1.

(2) Using cable assembly, connect alternator to alternator binding posts on test stand. Using test leads connect alternator output leads T1, T2, and T3 to ALTERNATOR T1, T2, and T3 binding posts (fig 2-3). Connect test lead D to ALTERNATOR D binding post and test lead E to ALTERNATOR E binding post.

(3) Install rectifier on rectifier mounting brackets (36, fig 2-7) and insert into rectifier chamber (6, fig 4-3) of test stand.

NOTE

Install rectifier so that rectifier plates are parallel to flow of air, and connectors are facing outward.

(4) Install cable assemblies, part numbers 48278 and 48277, into rectifier receptacles (fig 2-19) and connect to binding posts located in rectifier chamber (6, fig 4-3). Close rectifier chamber door.

(5) Install regulator on regulator mounting bracket (33 or 36, fig 2-7 and fig 2-6).

(6) Connect regulator cable assemblies to regulator receptacles (refer to fig 2-13) and regulator ac/dc terminals. Using test cable No. 48276 connect regulator G+ lead to REGULATOR G+ binding post (fig 2-3), regulator G- lead to REGULATOR G- binding post, and regulator F-B to REGULATOR F-B binding post. Using test cable No. 48275 connect regulator B+ lead to REGULATOR B+ binding post, regulator B- lead to REGULATOR B- binding post, regulator D lead to AC/DC SYSTEMS D binding post, regulator E lead to AC/DC SYSTEM E binding post, and regulator IGN lead to AC/DC SYSTEM IGN SW binding post.

(7) Connect ground lead between regulator case and REGULATOR GND binding post (fig 2-3).

(8) Install batteries in battery compartment (4, fig 4-3) of test stand and connect to proper binding posts on terminal board assembly in battery compartment (ref to para 2-3 and fig 2-8).

(9) Set POLARITY REVERSING switch (S7, fig 2-2) to NEG GND position.

(10) Set BATTERY CIRCUIT SELECTOR switch (S6, fig 2-2) to 24V position.

(11) Set FIELD CIRCUIT switch (S32, fig 2-2) to REGULATOR position.

(12) Set DC VOLTMETER OUTPUT VOLTAGE SELECT switch (S11, fig 2-1) to BAT position, MASTER LOAD DISCONNECT switch (S8, fig. 2-2) to ON position, observe battery voltage on DC VOLTMETER OUTPUT VOLTAGE meter (M2, fig 2-1), and then set DC VOLTMETER OUTPUT VOLTAGE SELECT (S11) switch to RECT GEN position.

(13) Position MASTER LOAD DISCONNECT switch (S8, fig 2-2) to OFF.

WARNING

Do not start the varidrive with a load applied.

(14) Start varidrive by pressing START pushbutton switch (S3, fig 2-4) and holding for no more than 30 seconds.

(15) Using SPEED CONTROL (fig 2-4), bring alternator up to minimum speed for rated output voltage (cut-in speed is approximately 2000 rpm).

(16) If regulator requires ignition input set AC/DC SYSTEMS IGN SW switch (S33, fig 2-3) to ON.

(17) Set MASTER LOAD DISCONNECT switch (S8, fig 2-2) to ON.

(18) Observe AC VOLTMETER OUTPUT VOLTAGE meter (M6, fig 2-1) and DC VOLTMETER OUTPUT VOLTAGE meter (M2).

(19) When rectifier dc voltage and ac voltage are indicated, rotate AC VOLTMETER OUTPUT VOLTAGE SELECT switch (S28, fig 2-1) to different phases to ascertain balanced phase condition.

(20) Rotate AC AMMETER OUTPUT CURRENT SELECT switch (S25, fig 2-1) to each of its positions to determine balanced phase condition.

(21) Vary alternator speed throughout speed range, closely observing rectifier dc voltage on DC VOLTMETER OUTPUT VOLTAGE meter (M2), ac voltage on AC VOLTMETER OUTPUT VOLTAGE meter (M6), and ac amperes on AC AMMETER OUTPUT CURRENT meter (M5).

(22) Using LOAD SELECTION switches (S17 through S24, fig 2-2) and MASTER LOAD DISCONNECT switch (S8), apply desired loading.

(23) When required, press AC/DC SYSTEMS EQUALIZER COIL TEST switch (S35, fig 2-3) and note drop-off of approximately 1.5 to 3.0 volts in output.

(24) Perform tests specified by manufacturer's specifications.

(25) Upon completion of tests, set AC/DC SYSTEMS IGN SW (S33, fig 2-3) to OFF, set BATTERY CIRCUIT SELECTOR switch (S6, fig 2-2), MASTER LOAD DISCONNECT switch (S8), and LOAD SELECTION switches (S17 through S24) to OFF.

(26) Reduce varidrive speed to one-quarter speed by turning SPEED CONTROL (fig 2-4) clockwise, and stop varidrive by pressing STOP pushbutton switch (S3).

(27) If no further tests are to be performed with test stand, set circuit breaker switch (CB1, fig 2-5) to OFF.

(28) For manual control of field current (fig 2-15), make sure that DC VARIABLE POWER SUPPLY 0-32 VDC control (T5, fig 2-4), is fully counterclockwise. Connect harness 48296 (-D) from regulator D binding post (fig 2-3) to black DC VARIABLE VOLT OUTPUT binding post (fig 2-2) Set EXTERNAL FIELD EXCITER AC SYSTEM switch (S31) and DC VARIABLE VOLTS switch (S10) to ON. Set FIELD CIRCUIT switch, (S32) to MANUAL position and FIELD CURRENT 0-30 AMPS (MAX) control (R26) fully clockwise. Slowly increase setting of DA VARIABLE POWER SUPPLY 0-32 VDC control (T5, fig 2-4) to control field current.

e. Testing AC/DC Systems (Internal, Regulator/Rectifier)

NOTE

This test procedure is only a typical test procedure.

(1) Position test stand controls in accordance with table 2-1.

(15) Using LOAD SELECTION switches (S17 through S24, fig 2-2) and VARIABLE LOAD control (R32), as applicable, increase load on generator until rated load is reached, and vary generator speed throughout speed range.

(16) Shock test generator and regulator, using MASTER LOAD DISCONNECT switch (S8, fig 2-2), noting regulated voltage. Set switch to OFF, then to ON to shock load.

(17) Increase loading slowly and observe slight drop off in regulated voltage and leveling off of current reading when current limiter comes into play.

(18) Decrease load to zero by setting all LOAD SELECTION switches (S17 through S24, fig 2-2) and MASTER LOAD DISCONNECT switch (S8, fig 2-2) to OFF.

(19) Set AC/DC SYSTEMS IGN SW switch (S33, fig 2-3) to OFF.

(20) Set BATTERY CIRCUIT SELECTOR switch (S6, fig 2-2) to OFF.

(21) Set FIELD CIRCUIT switch (S32, fig 2-2) to OFF position.

(22) Reduce varidrive speed to one-quarter speed by turning SPEED CONTROL (fig 2-4) clockwise, and stop varidrive by pressing STOP pushbutton switch (S2, fig 2-4).

f. Testing Starters (Cranking Motors).

(1) Precautions. Observe following precautions when testing starters:

- (a) Make sure starters are correctly mounted.
- (b) Adjust voltage properly for unit under test.

(2) Testing.

NOTE

This test procedure is only a typical procedure.

(a) Position test stand controls in accordance with table 2-1.

(b) Install starter on test stand, as dictated by mounting characteristics:

1. Chain mounting assembly (7, fig 2-10) will accommodate many open-jaw starters, providing that body of starter can be secured by chain vise. This mounting will also accommodate many hooded jaw starters, but it may be easier to flange mount hooded jaw starters on bracket.

2. Starter mounting bracket (38, fig 2-7) is designed specifically for flange mounting of starters.

g. Testing Free Running (No Load) Starters.

CAUTION

There are some starter motors for which manufacturers recommend that free running tests be conducted at voltages considerably below nominal voltage rating of motor. Be sure that tests are conducted in accordance with procedures recommended by manufacturer.

NOTE

Some starters must be connected to AC/DC SYSTEMS ING SW binding post (S33, fig 2-3). With all LOAD SELECTION switches (S17 through S24, fig 2-2) set to OFF, set MASTER LOAD DISCONNECT switch (S8) to ON, and set BATTERY CIRCUIT SELECTOR switch (S6) to proper voltage setting.

- (1) Install starter on test stand.
- (2) Connect power leads from starter to appropriate starter terminals. (Refer to fig 2-27, 2-28 and 2-29.)
- (3) Connect test leads from starter cable connections to STARTER FREE RUN binding post (fig 2-3) and STARTER COMMON binding post.
- (4) Connect EXTERNAL DC VOLTAGE INPUT binding posts (fig 2-2) to starter input.
- (5) Set DC VOLTMETER OUTPUT VOLTAGE SELECT switch (S11, fig 2-1) to EXT position.
- (6) Set DC AMMETER LOAD & STARTER OUTPUT CURRENT BATTERY CHARGE CURRENT RANGE switch (S14, fig 2-1) to STARTER X4 position.
- (7) Set STARTER TEST switch (S9, fig 2-2) to ON.
- (8) Adjust STARTER RHEOSTAT control (R18, fig 2-2) clockwise while monitoring voltage and current for appropriate settings.
- (9) Check rpm of starter with hand tachometer (vibration type).
- (10) Perform tests specified by starter manufacturer.
- (11) Adjust STARTER RHEOSTAT control (R18, fig 2-2) to near full resistance position by rotating in counterclockwise direction, maintaining slight pressure on carbon stack.
- (12) Upon completion of tests, position STARTER TEST switch (S9, fig 2-2) to OFF and MASTER LOAD DISCONNECT switch (S8, fig 2-2) to OFF .

h. Use of DC Generator for Starter Testing.

(1) It is possible to provide dc power for free running starter tests by means of a dc aircraft type generator, driven by output shaft (1, 3, fig 1-2) of varidrive. Cooling air for generator must be supplied by external blower. Proceed as follows:

CAUTION

Depending upon voltage and current rating of starter under test, it may be necessary to use generator of corresponding output voltage. In some instances, it will be possible to use a 24 volt generator for lower voltage starter tests by dropping output voltage through adjustment of a regulator, speed of generator, and setting of starter rheostat on test stand.

(a) Install dc generator on mounting bracket and connect to proper output shaft (1, 3, fig 1-2) by means of splined coupling and adapter (6, 5, fig 2-9). Then, terminals of generator and its associated regulator are connected through test stand circuitry to provide field current control by means of FIELD CURRENT 0-5 AMPS (MAX) control (R27, fig 2-2). Connect generator (+) to STARTER INPUT binding post (fig 2-3) and generator (-) to GENERATOR G- binding post. A jumper link must be installed between REGULATOR B- binding post and REGULATOR G- binding post. Install a jumper between starter input and GENERATOR G+ binding post.

NOTE

Before operating generator, make certain that POLARITY REVERSING SWITCH (S7, fig 2-2) is set to appropriate position.

(b) Perform free running test in same manner as described above, except with BATTERY CIRCUIT SELECTOR switch (S6, fig 2-2) set to OFF.

NOTE

The output voltage of the dc generator may best be controlled by controlling the field current by use of the field rheostat and operating the generator at some speed below base speed. Since final adjustment of voltage and speed may be necessary when the generator is under load, care should be exercised to prevent ceiling volts and specified field current being exceeded when load is removed. FIELD CURRENT 0-5 AMPS (MAX) control (R27, fig 2-2) is rated at 5 amperes; therefore, DC AMMETER FIELD CURRENT meter

(M7, fig 2-1) should be observed carefully and this control should not be used when field current exceeds 5 amperes. FIELD CURRENT 0-30 AMPS (MAX) control (R26, fig 2-2) is used alone when testing combat fleet (aircraft) type generators which normally use a carbon pile type regulator.

i. DC Variable Voltage Supply.

(1) A DC VARIABLE VOLTAGE POWER SUPPLY (T5, fig 2-4) is available for the testing of relay pick-up and drop-out voltages. supply is rated at 0 to 32 volts dc, 15 amperes. This power supply may be used with or without the varidrive running and is independent of the batteries.

(2) Associated with this power supply circuit is the VAR position of DC VOLTMETER OUTPUT VOLTAGE SELECT switch (S11, fig 2-1). When this switch is positioned in the VAR position it will indicate the output voltage of the DC variable power supply.

(3) Also provided with this circuit are two DC VARIABLE VOLTS OUTPUT binding posts (fig 2-2) and a DC VARIABLE VOLTS switch (S10). The dc variable voltage is available at the two binding posts.

(4) To operate the variable dc voltage power supply (T5, fig 2-4) proceed as follows:

(a) Position all switches and controls in accordance with table 2-1.

(b) Connect the relay coil by use of test leads to DC VARIABLE VOLTS OUTPUT binding posts (fig 2-2).

CAUTION

To prevent damage to components being tested always ascertain component characteristics as published by component manufacturer prior to the application of power.

(c) Verify that DC VARIABLE POWER SUPPLY 0-32 VDC control (T5, fig 2-4) is fully counterclockwise.

(d) Position DC VOLTMETER OUTPUT VOLTAGE RANGE switch (S12, fig 2-1) to the X5 position.

(e) Position DC VOLTMETER OUTPUT VOLTAGE SELECT switch (S11) to the VAR position.

(f) Open the high voltage compartment door and position main circuit breaker switch (CB1, fig 2-5) to the ON position.

(g) Position DC VARIABLE VOLTS switch (S10, fig 2-2) to the ON position.

(h) Increase DC VARIABLE POWER SUPPLY 0-32 VDC control (T5, fig 2-4) slowly clockwise observing the dc voltage and operation of the relay.

(i) DC VOLTMETER OUTPUT VOLTAGE RANGE switch (S12, fig 2-1) may be re-positioned to obtain a lower range to yield greater accuracy of applied dc volts.

(j) After completion of tests, decrease DC VARIABLE POWER SUPPLY 0-32 VDC control (T5, fig 2-4) fully counterclockwise, and set DC VARIABLE VOLTS switch (S10, fig 2-2) and circuit breaker switch (CB1, fig 2-5) to the OFF position.

j. Relay Contacts Test.

(1) A test indicator circuit capable of being used for visual indication of relay contact closure is provided.

(2) This test circuit may be used in conjunction with the dc variable voltage supply to perform complete relay/contact testing.

(3) Operation of this relay contact test is as follows:

(a) Position all switches and controls in accordance with table 2-1.

(b) Connect the relay coil by use of test leads to DC VARIABLE VOLTS OUTPUT binding posts (fig 2-2).

(c) Connect the relay contacts by use of test leads to RELAY CONTACTS INPUT binding posts (fig 2-2).

CAUTION

To prevent damage to components being tested always ascertain component characteristics as published by component manufacturer prior to the application of power.

(d) Verify that DC VARIABLE POWER SUPPLY 0-32 VDC control (T5, fig 2-4) is fully counterclockwise.

(e) Position DC VOLTMETER OUTPUT VOLTAGE RANGE switch (S12, fig 2-1) to the X5 position.

(f) Position DC VOLTMETER OUTPUT VOLTAGE SELECT switch (S11) to the VAR position.

(g) Open the high voltage compartment door (5, fig 4-3) and position circuit breaker switch (CB1, fig 2-5) to the ON position.

(h) Position DC VARIABLE VOLTS switch (S10, fig 2-2) to the ON position.

(i) Increase DC VARIABLE POWER SUPPLY 0-32 VDC control (T5, fig 2-4) slowly clockwise observing CONTACT CLOSURE indicator light (DS7, fig 2-2).

(j) Operation of the relay is indicated by CONTACT CLOSURE indicator light (DS7). When the relay contacts are closed, the indicator light will illuminate. When relay contacts are open, the indicator will not illuminate.

(k) The DC VOLTMETER OUTPUT VOLTAGE RANGE switch (S12, fig 2-1) may be re-positioned to obtain a lower range to yield greater accuracy of applied dc volts.

(l) After completion of tests, decrease DC VARIABLE POWER SUPPLY 0-32 VDC control (T5, fig 2-4) fully counterclockwise, and position DC VARIABLE VOLTS switch (S10, fig 2-2) and circuit breaker switch (CB1, fig 2-5) to the OFF position.

k. Battery Charge Circuit.

(1) A manually operated battery charge circuit is provided. This circuit may be used for the charging of 6, 12 or 24 volt batteries and has current adjustment from 2.5 to 20 amperes. The charge circuit also incorporates a 2-hour (120 minutes) timer. This circuit is operable with or without the varidrive operating.

(2) Battery charging is accomplished with the batteries connected in electrical series.

(3) If batteries are to be changed externally, disconnect all internal batteries and connect the external battery NEGATIVE terminal to the COM terminal in the battery compartment and the battery PLUS terminal to the 24 volt terminal in the battery compartment.

(4) General battery information.

NOTE

Refer to TM 9-6140-200-14 for maintenance of lead-acid storage batteries.

(a) The battery should be carefully inspected before actually being put on charge.

1. Inspect battery posts, clamps and cables for breakage, loose connections, corrosion, cracked or warped case, raised cell covers and other faults.

2. Inspect electrolyte level. If electrolyte is below the top of the plates, add water. If not below the plates, make hydrometer test.

3. Note ampere-hour or other rating of battery.

(5) Charging of Batteries.

WARNING

Hydrogen gas is given off during battery charging. Provide adequate ventilation to remove accumulated gases; otherwise, a spark could cause an explosion.

(a) Observe following precautions:

1. Charge batteries at rate specified by manufacturer.

2. Do not charge batteries at a high rate for excessively long periods.

3. When using high rate of charge, be certain that battery temperature and specific gravity of electrolyte of all cells are checked often enough to prevent thermal breakdown and electrolysis.

(b) When checking electrolyte with a hydrometer, observe the following:

1. Hold the tube of hydrometer vertical.

2. Do not suck too much electrolyte into tube.

3. Hydrometer float must be freely suspended in electrolyte.

4. Take readings at eye level.

5. A fully charged battery should read 1.265 to 1.290 at 80°F. For higher temperatures, add four gravity points for each 10°F above 80°F and for lower temperatures, subtract four gravity points for each 10°F below 80°F.

(c) Position test stand controls in accordance with table 2-1.

(d) Set DC VOLTMETER OUTPUT VOLTAGE SELECT switch (S11, fig 2-1) to BAT position and MASTER LOAD DISCONNECT switch (S8, fig 2-2) to ON position and monitor battery charging voltage (M3, fig 2-1).

(e) Position circuit breaker switch (CB1, fig 2-5) to ON.

(f) Position CHARGE TIMER (MINUTES) control (TD1, fig 2-4) to the desired charge time.

(g) While holding DC AMMETER LOAD & STARTER OUTPUT CURRENT BATTERY CHARGE CURRENT PRESS FOR BATTERY CHARGE RATE switch (S15, fig 2-1) in the up position, increase BATTERY CHARGE CIRCUIT control (T3, fig 2-4) until the desired rate of current is attained as indicated by DC AMMETER LOAD & STARTER OUTPUT CURRENT BATTERY CHARGE CURRENT meter (M3, fig 2-1) on the 0-50 (X1) ampere scale. Observe the battery voltage also (M2, fig 2-1).

(h) CHARGE INDICATOR (DS8, fig 2-4) will remain illuminated for the duration of charging time.

(i) Check rate of charge current periodically and adjust current as necessary to maintain proper charge rate.

(j) After battery has been charged, be certain that the CHARGE TIMER (MINUTES) control (TD1, fig 2-4) is at zero, rotate BATTERY CHARGE CIRCUIT control (T3, fig 2-4) full counterclockwise, and position MASTER LOAD DISCONNECTOR switch (S8, fig 2-2) and circuit breaker switch (CB1, fig 2-5) to OFF.

1. Vibration Tachometer.

(1) The vibration tachometer (34, fig 2-7) is of the vibrating reed type and indicates speed when placed against the case of the rotating apparatus.

(2) This tachometer is furnished for indicating speeds of starters during the free running tests. Since the shaft of all starters is not accessible for use of tips, this type of tachometer must be used.

(3) As with any indicating device, it is advisable to calibrate it with a "Strobotac" or some other accurate means. Under tests with "Strobotacs" and other dial type speed indicating instruments, these tachometers have been found to be very accurate.

(4) Since there is no adjustment on this tachometer except for the manner in which it is placed against the case of the rotating apparatus, the correction determined during calibration should be marked on the carrying case.

(5) The vibration tachometer is used in the following manner:

(a) Hold the long edge of the tachometer firmly on the case of the starting motor, being sure not to restrict the movement of the reed.

(b) Move the tuning slide up and down the scale until the reed reaches maximum vibration.

(c) Read the speed opposite the slide arrow,

(d) Further instructions for other uses of this tachometer are included in the carrying case.

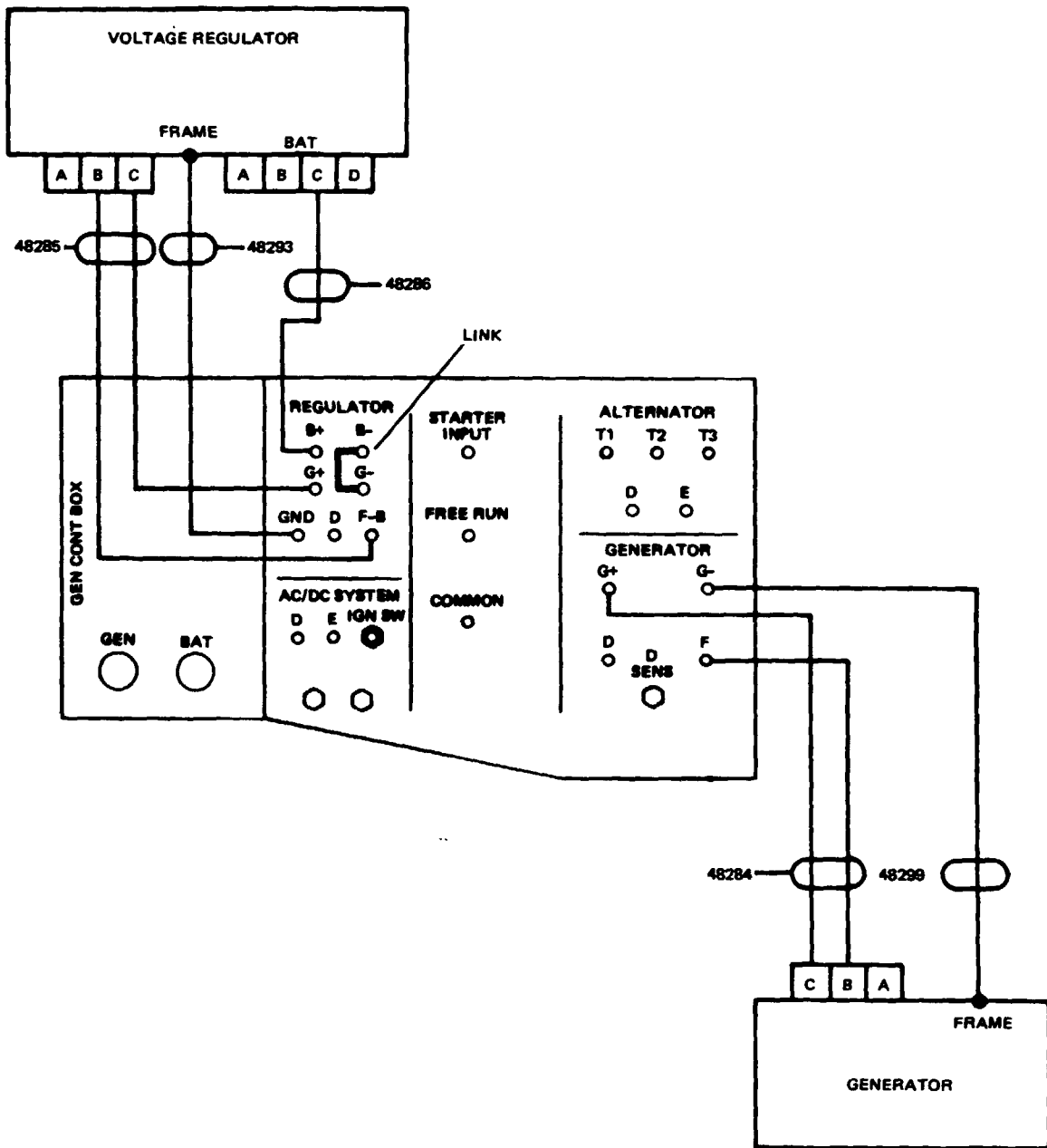

Refer to para 2-9b for test procedures.

Figure 2-12. Typical system interconnections, 25 ampere DC generator with regulator.

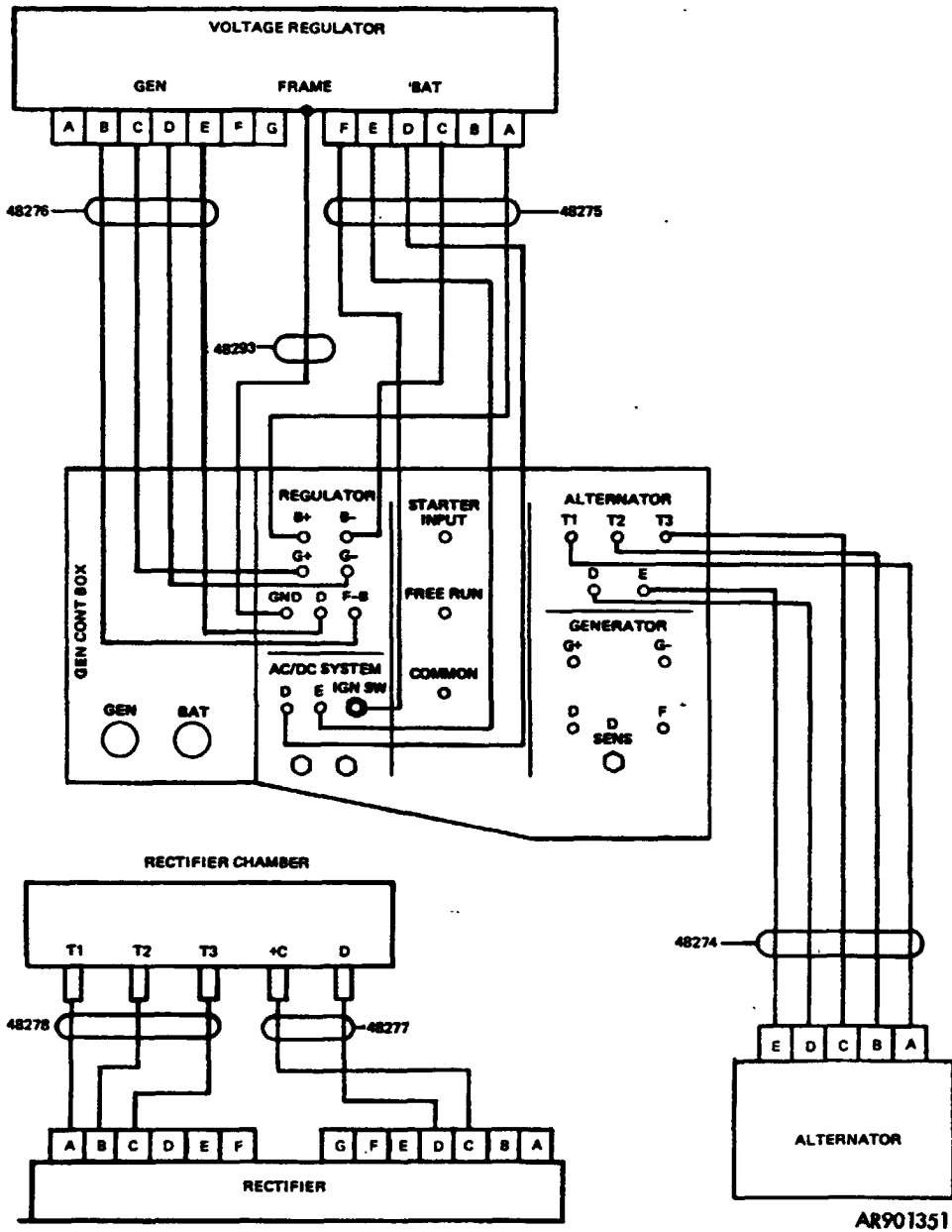

Refer to para 2-9d for test procedures.

Figure 2-13. Typical system interconnections, 100 ampere AC/DC system with voltage regulator and rectifier.

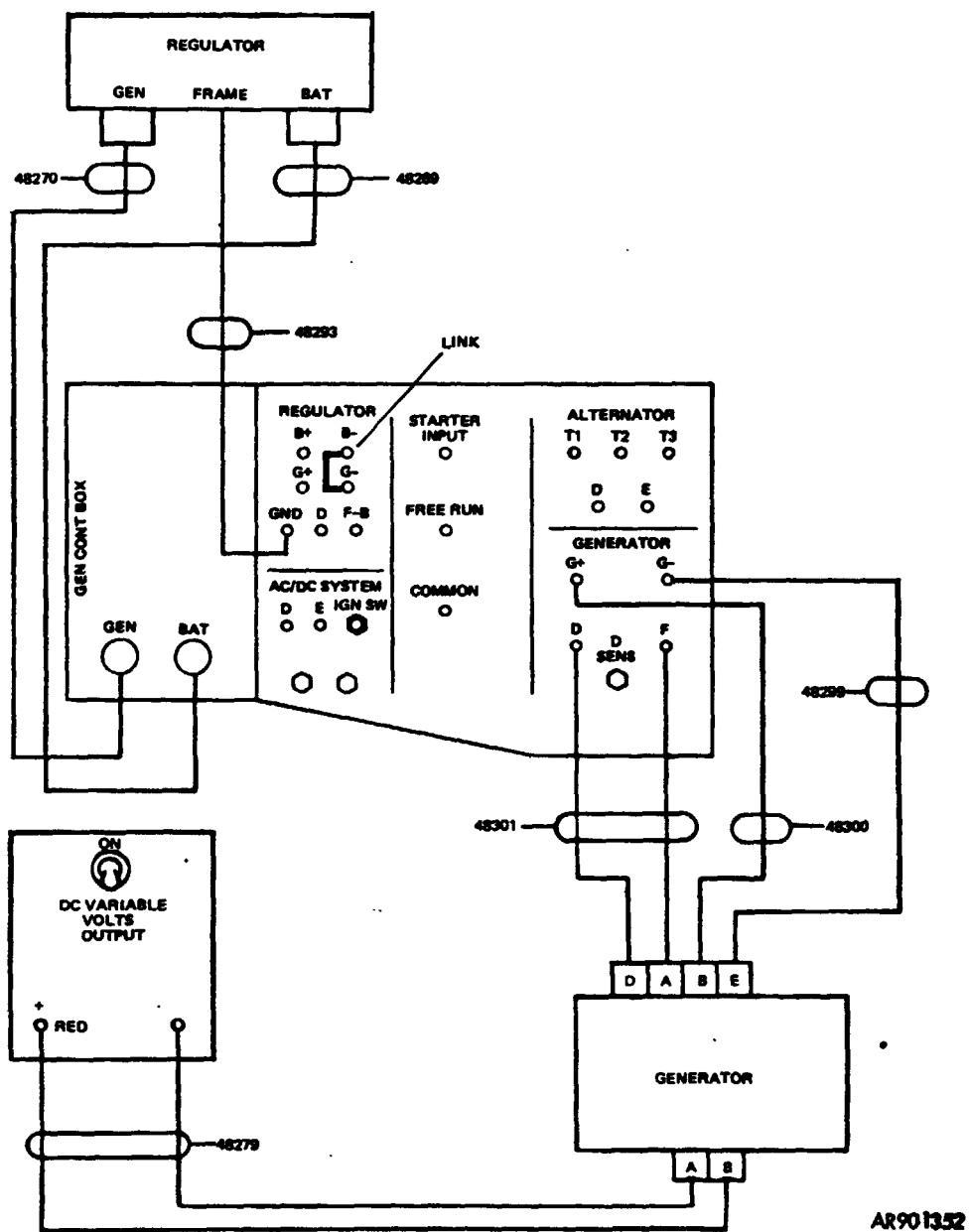

AR901352

Refer to para 2-9b for test procedures.

Figure 2-14. Typical system interconnections, 300 ampere DC generator with fan and regulator.

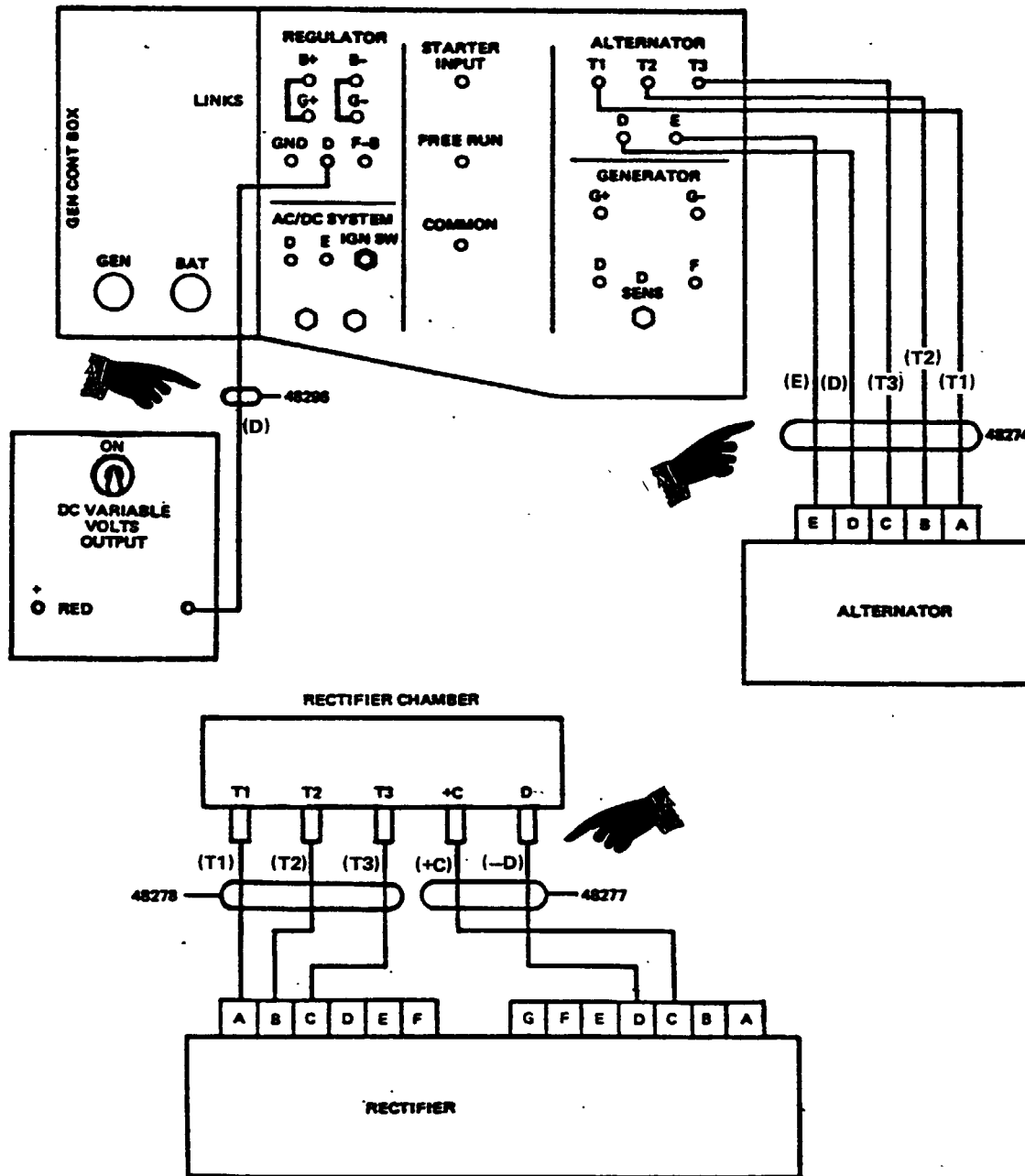

Figure 2-15. Typical system interconnections, 100 ampere alternator with rectifier, manual field control.

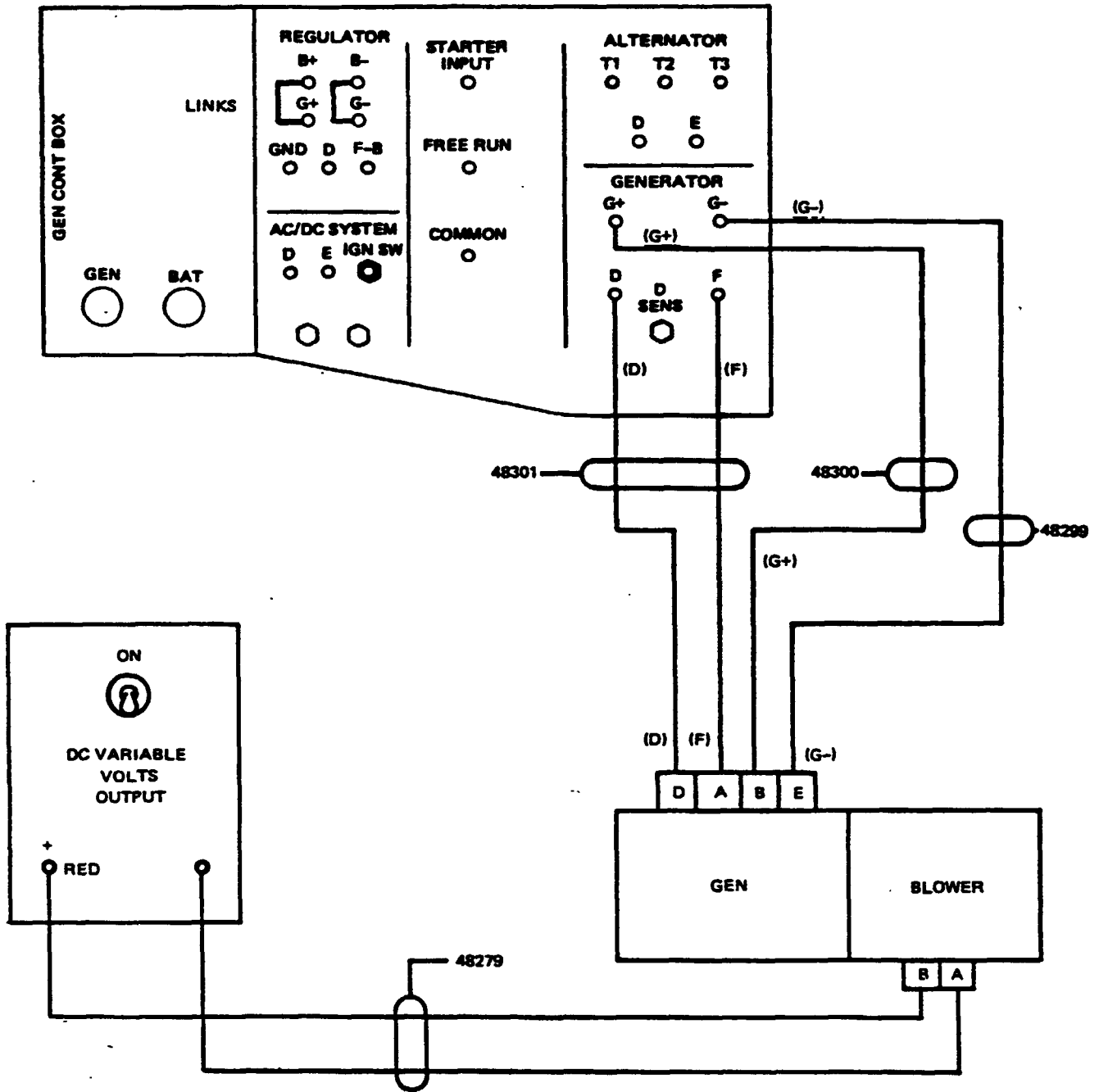

Figure 2-16. Generator connection, 300 ampere, 30 vdc generator (Army P/N 10889713, Lear Siegler G-22-6F-0; Army P/N 10889998, Lear Siegler G-22-7-F-0).

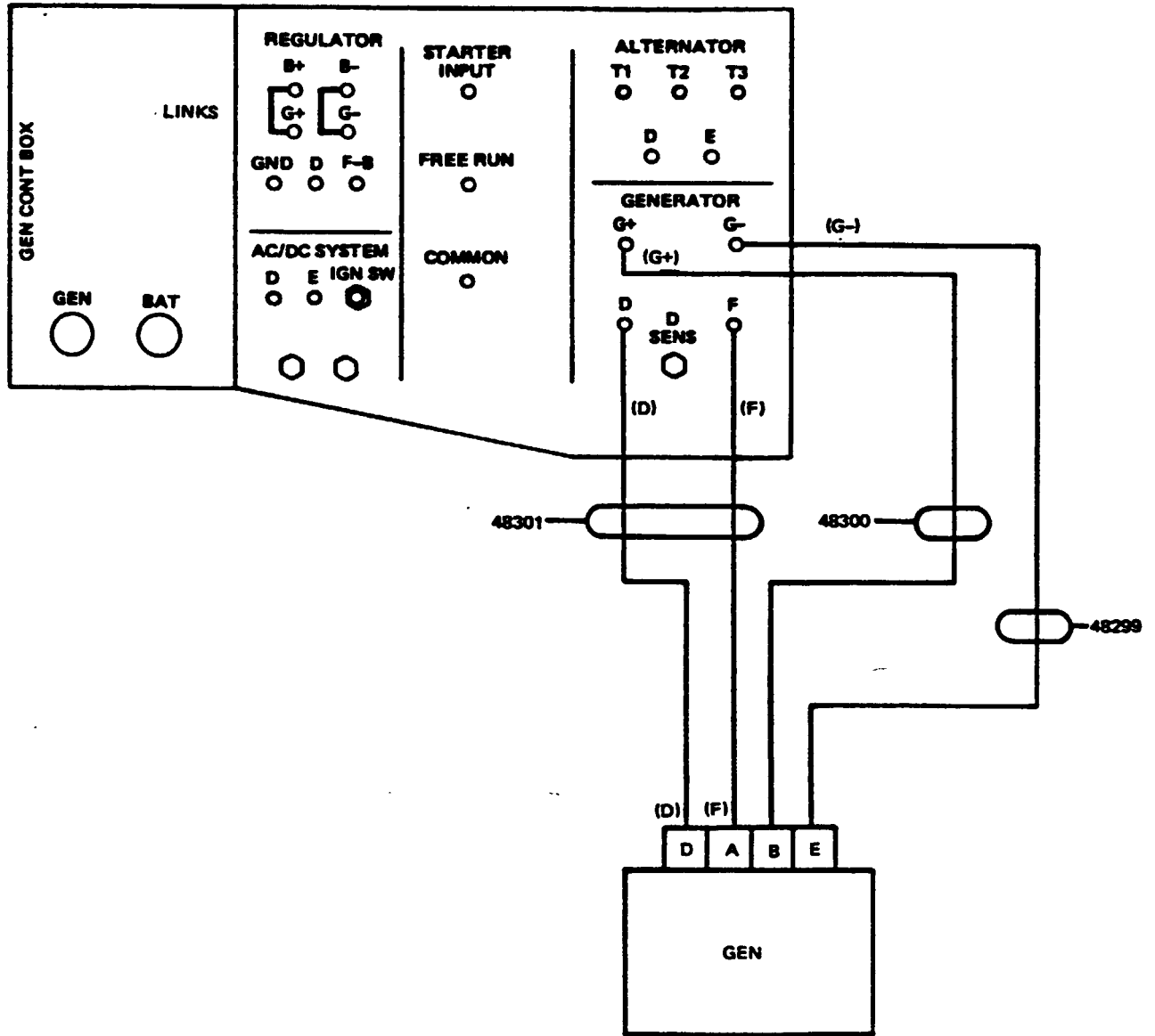

Figure 2-17. Generator connection, 300 ampere, 30 vdc generator (Army P/N 10914831, Lear Siegler G-22-9).

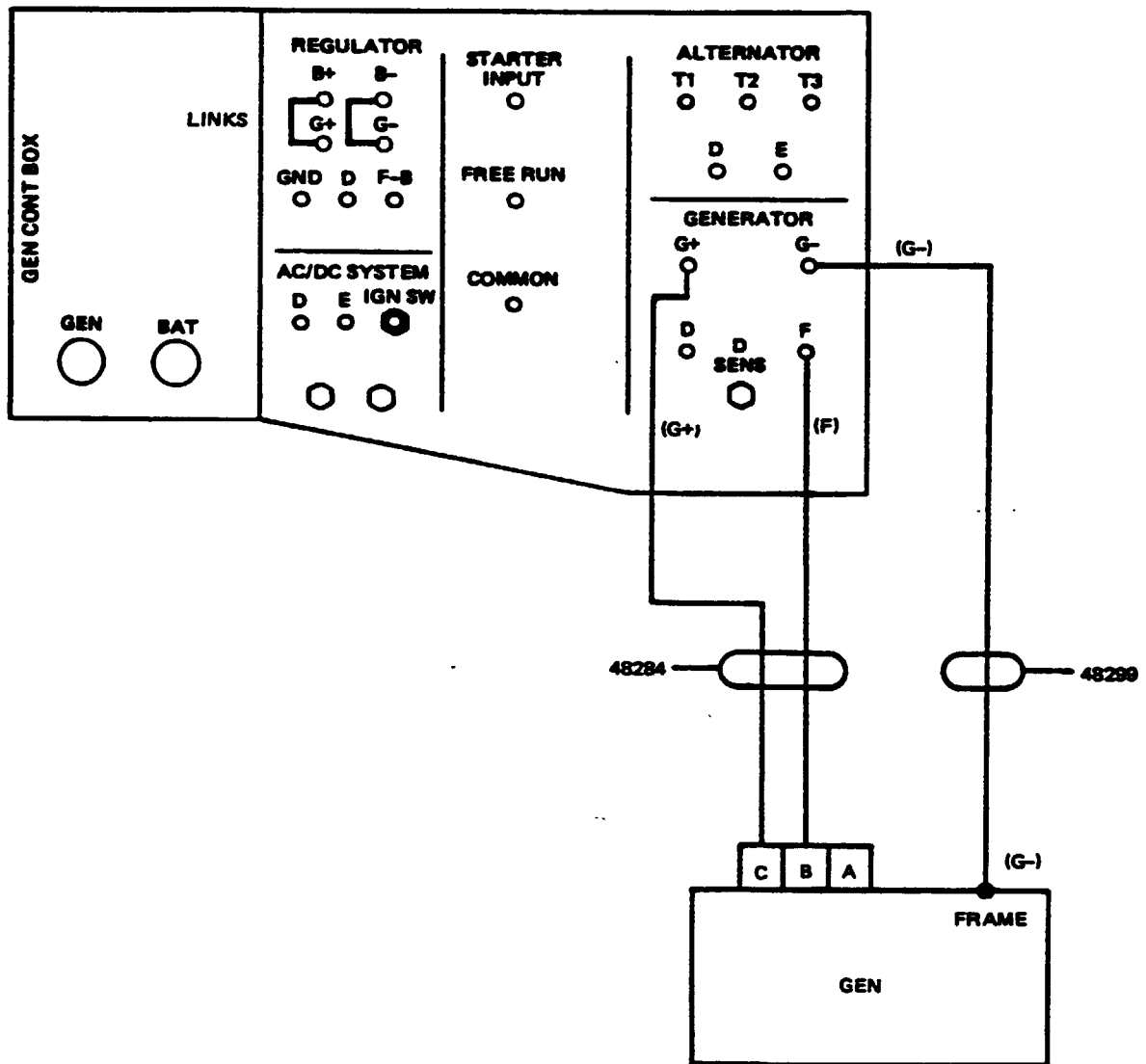

Figure 2-18. Generator connection, 25 ampere, 28 vdc generator (Army P/N 10950808-1, Prestolite GHA-4804UT).

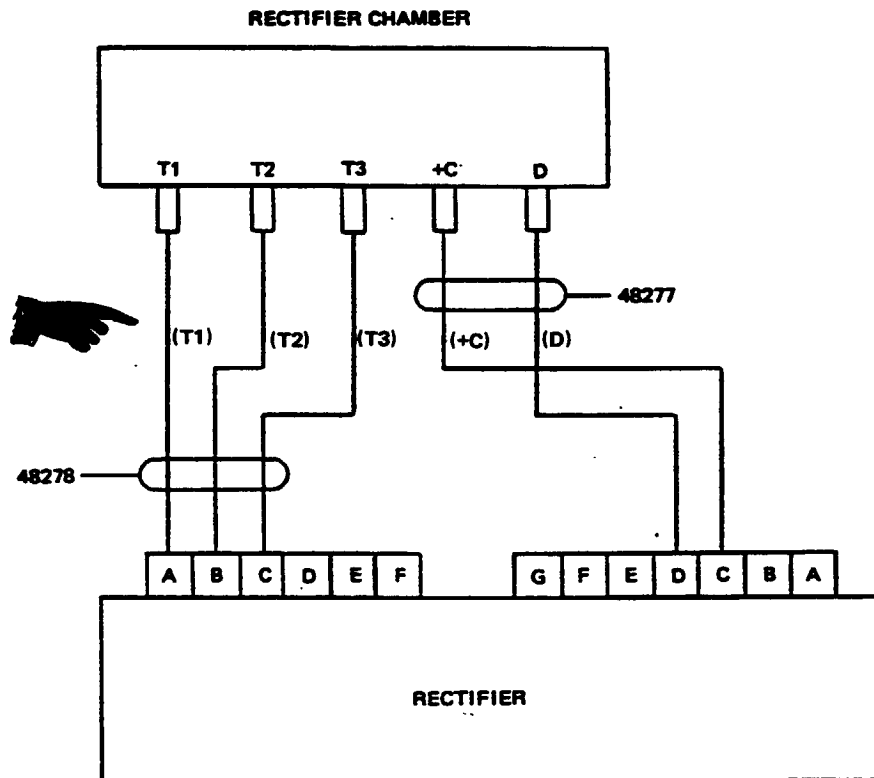

Figure 2-19. Rectifier connection, 100 ampere ac/dc (Army P/N 11640182, Leece Neville C00111100A; Army P/N 7954343, Leece Neville 1029CP; Army P/N 10906314, Leece Neville 1106CA).

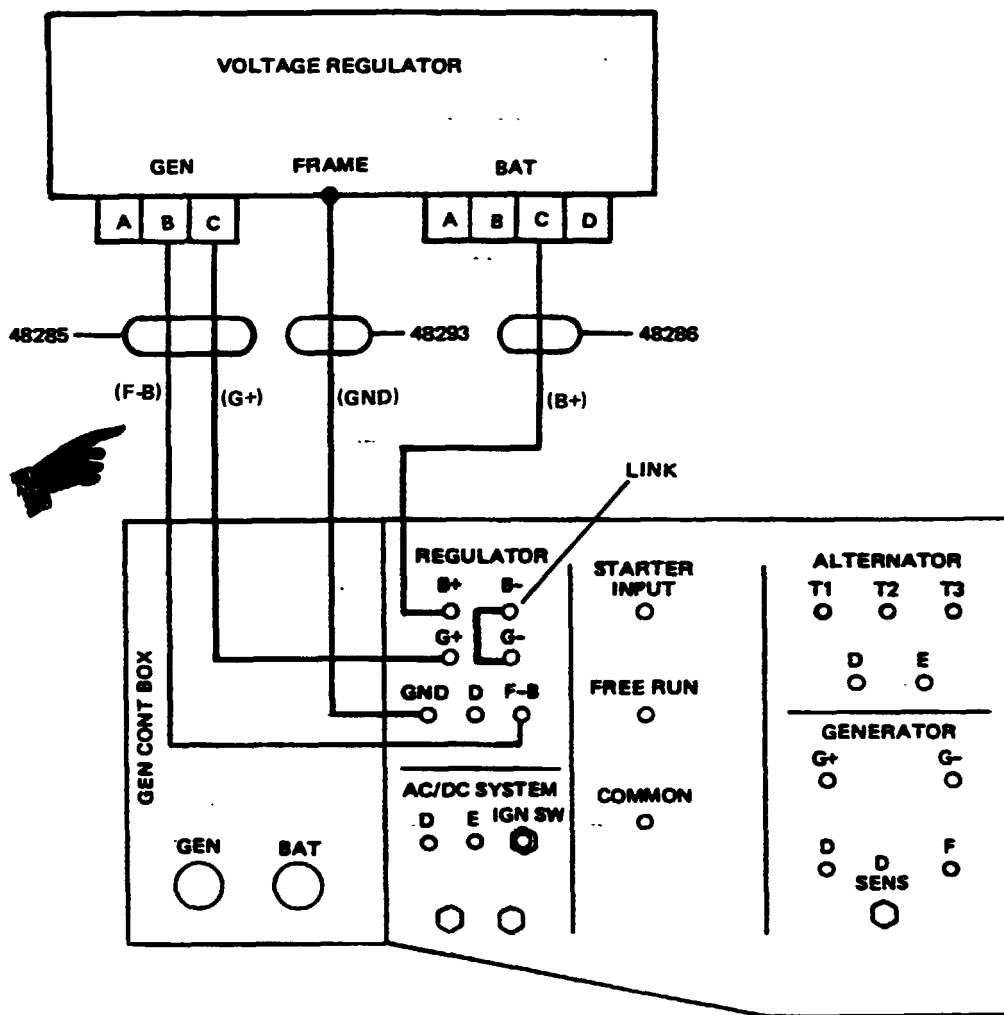

Figure 2-20. Voltage regulator connection, 25 ampere, 24 vdc (Army P/N 7351952, Delco Remy 1118424; Army P/N 8360020, Delco Remy 1118656; Army P/N 8712283, Prestolite PRJBC-4004UT; Army P/N 11631857, Vapour 26640473-04).

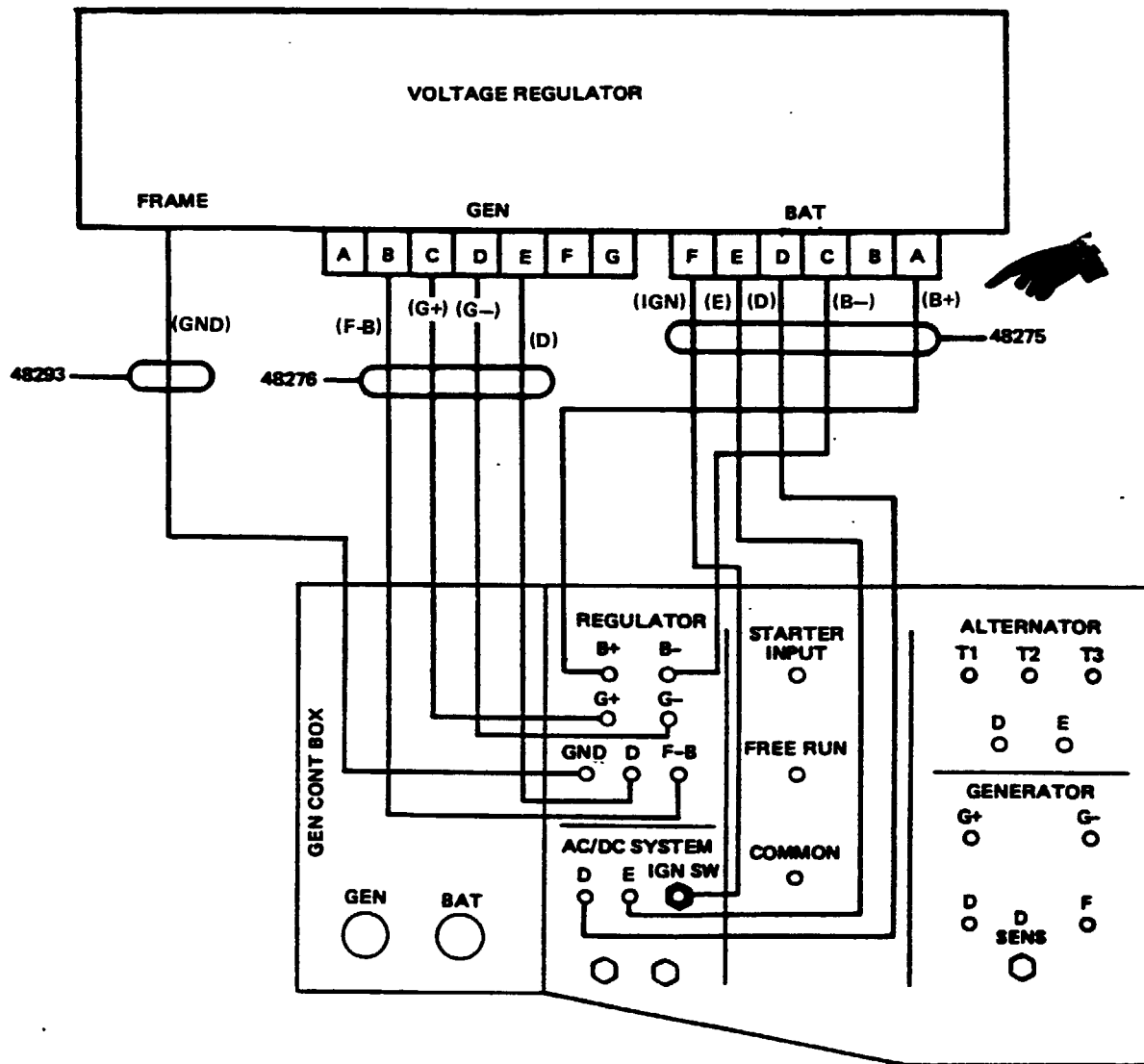

Figure 2-21. Voltage regulator connection, 25 ampere, 24 vdc (Army P/N 10947439, Vapor 2644001-05) and 100 ampere, 28 vdc (Army P/N 11640367, Leece Neville 91040 (5073RB)).

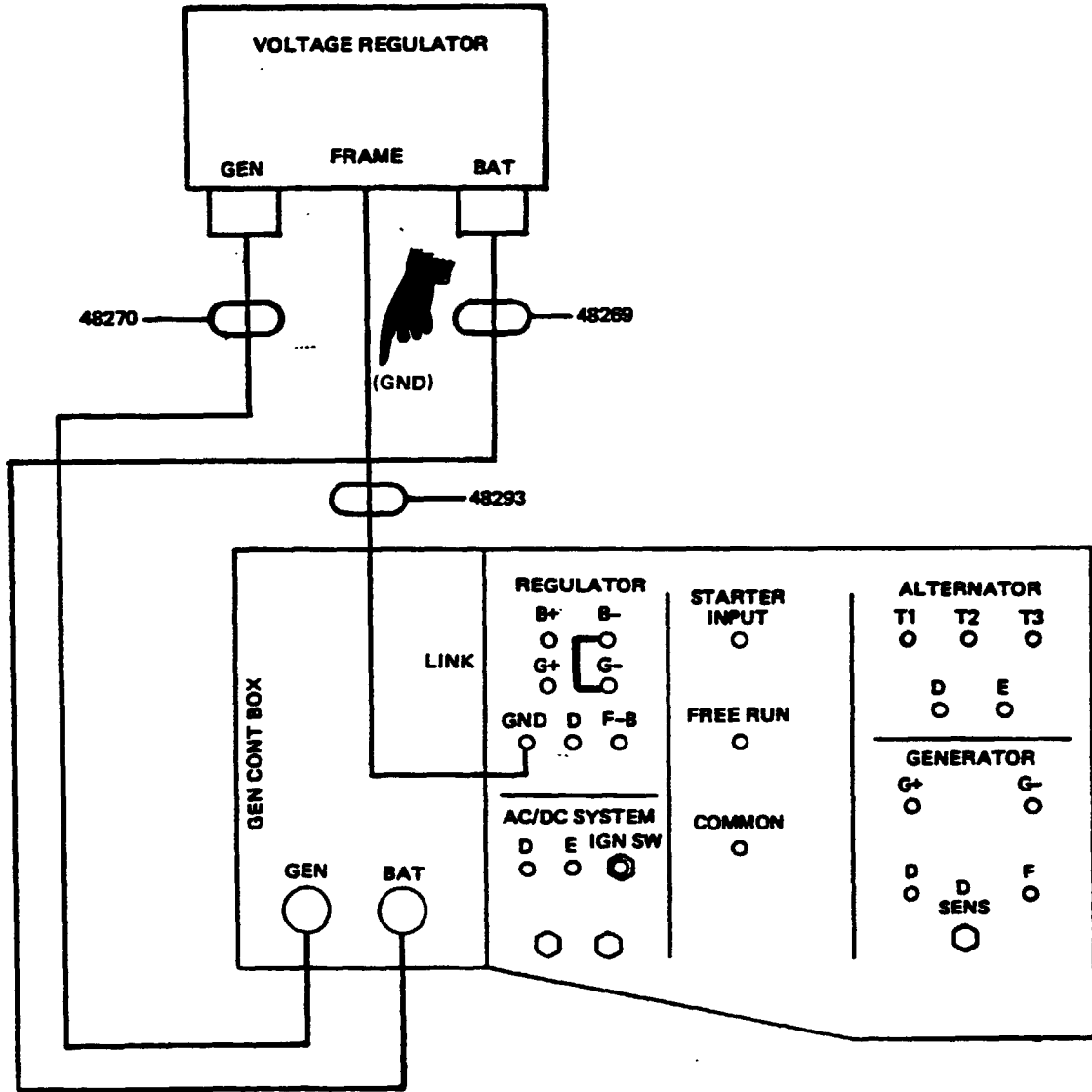

Figure 2-22. Voltage regulator connection, 300 ampere, 28 vdc (Army P/N 11621812, Vapor 26540208-03).

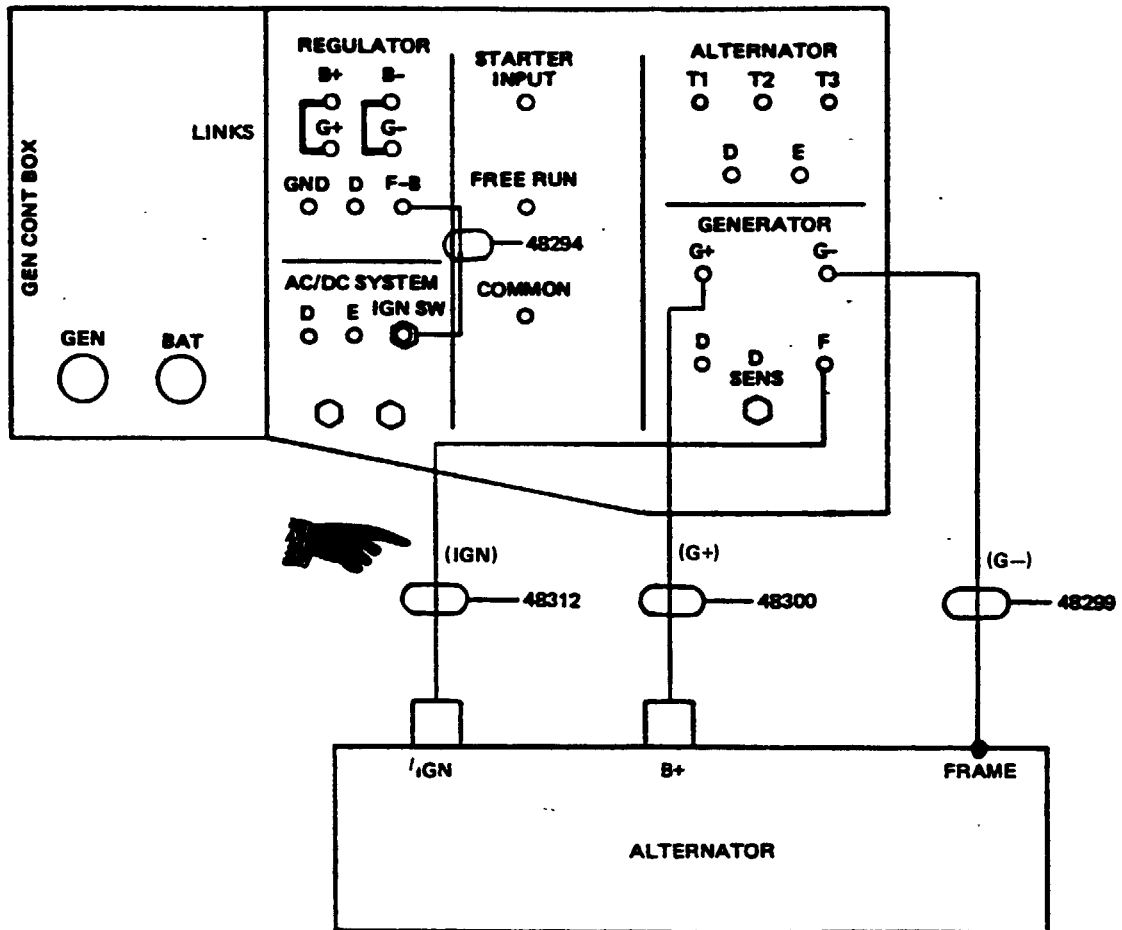

Figure 2-23. Alternator connection, 60 ampere, 28 vdc (Army P/N 10929868, Prestolite AMA-5103UT).

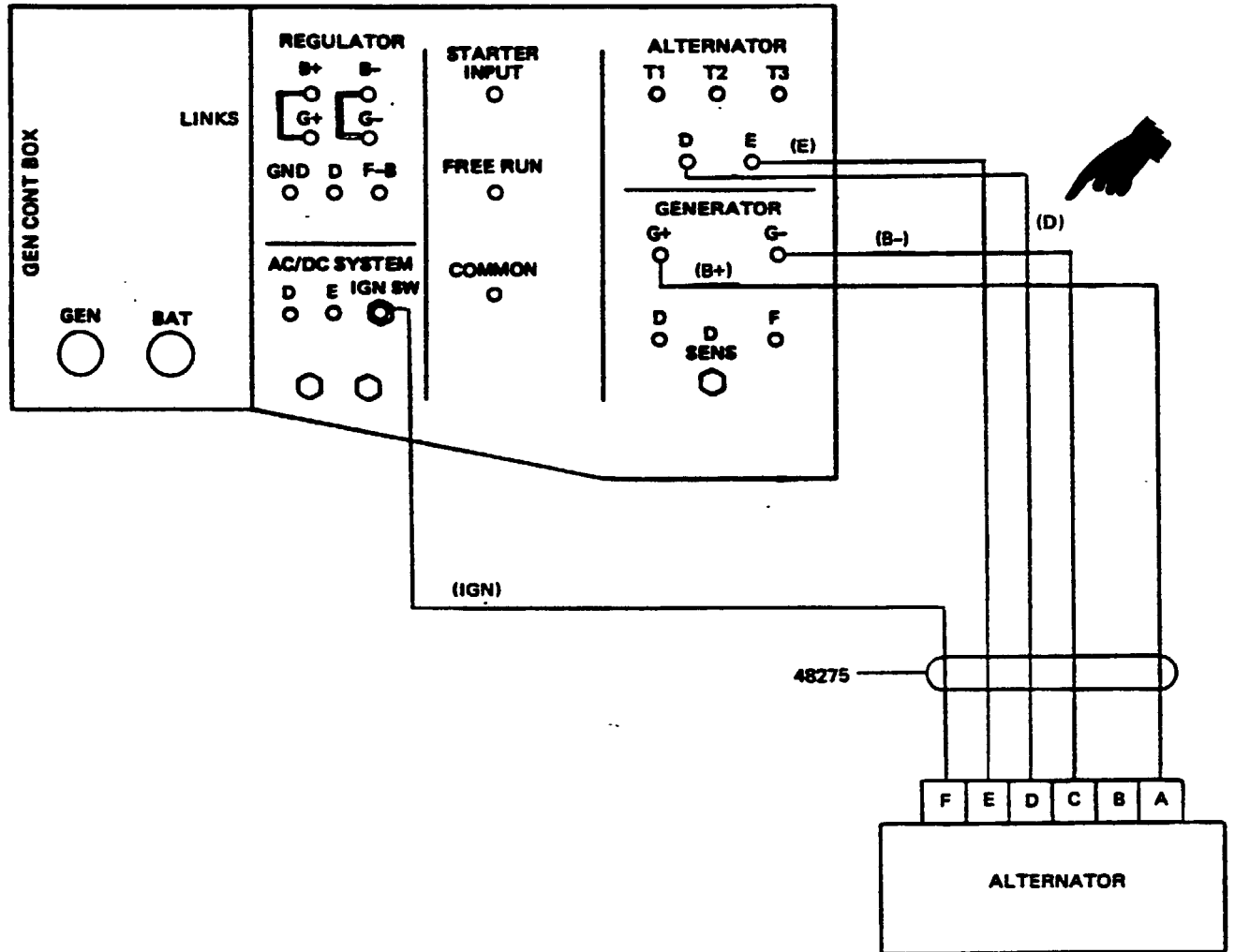

Figure 2-24. Alternator connection, 100 ampere, 28 vdc, (Army P/N 11613630, Leece Neville A001-3018-AB).

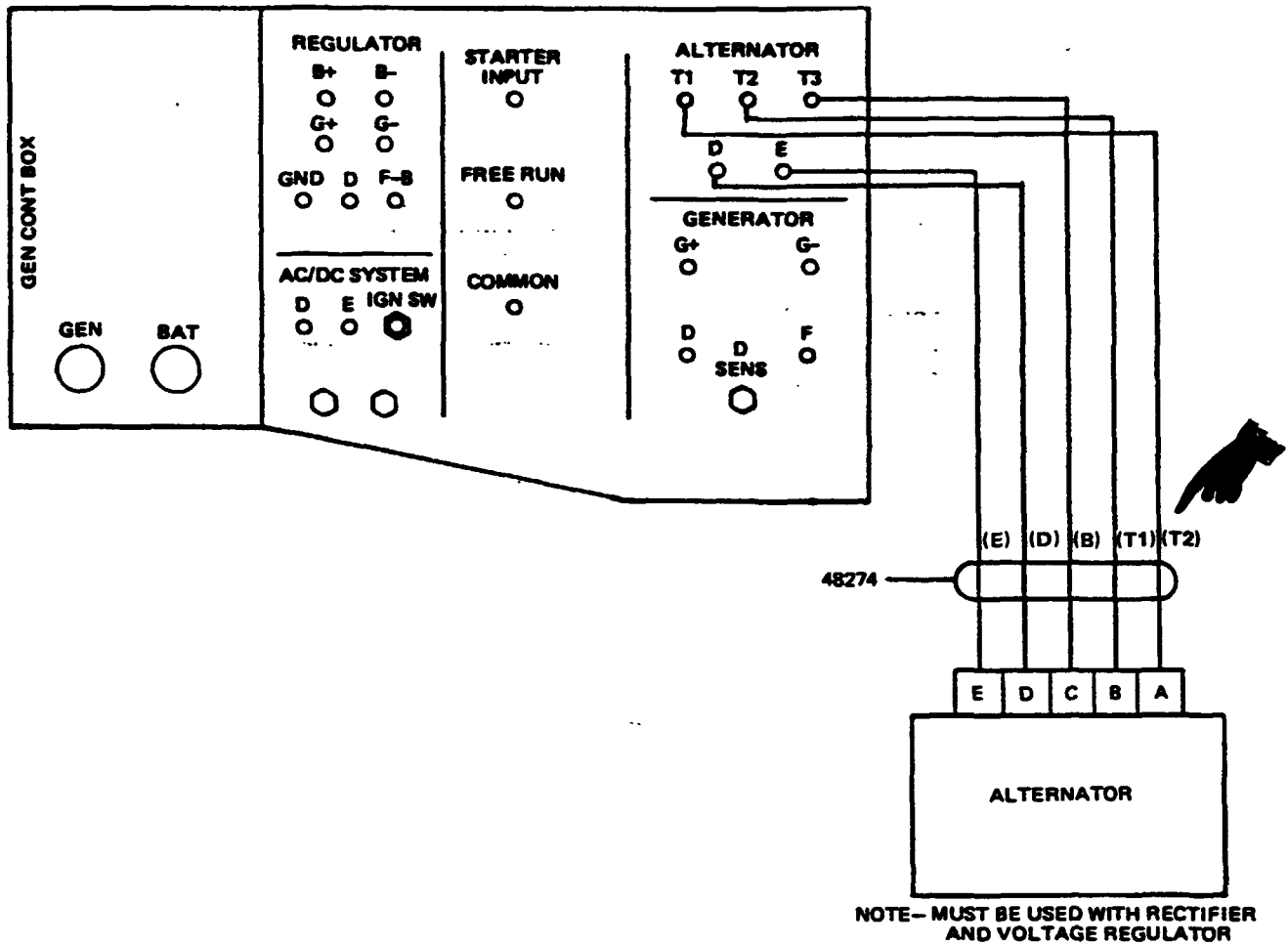

Figure 2-25. Alternator connection, 100 ampere ac/dc system (Army P/N 10922191, Leece Neville A0015504AB; Army P/N 8376691, Leece Neville A0015320GP; Army P/N 1164980, Leece Neville A0015516AA; Army P/N 7954722, Leece Neville A0015258GS).

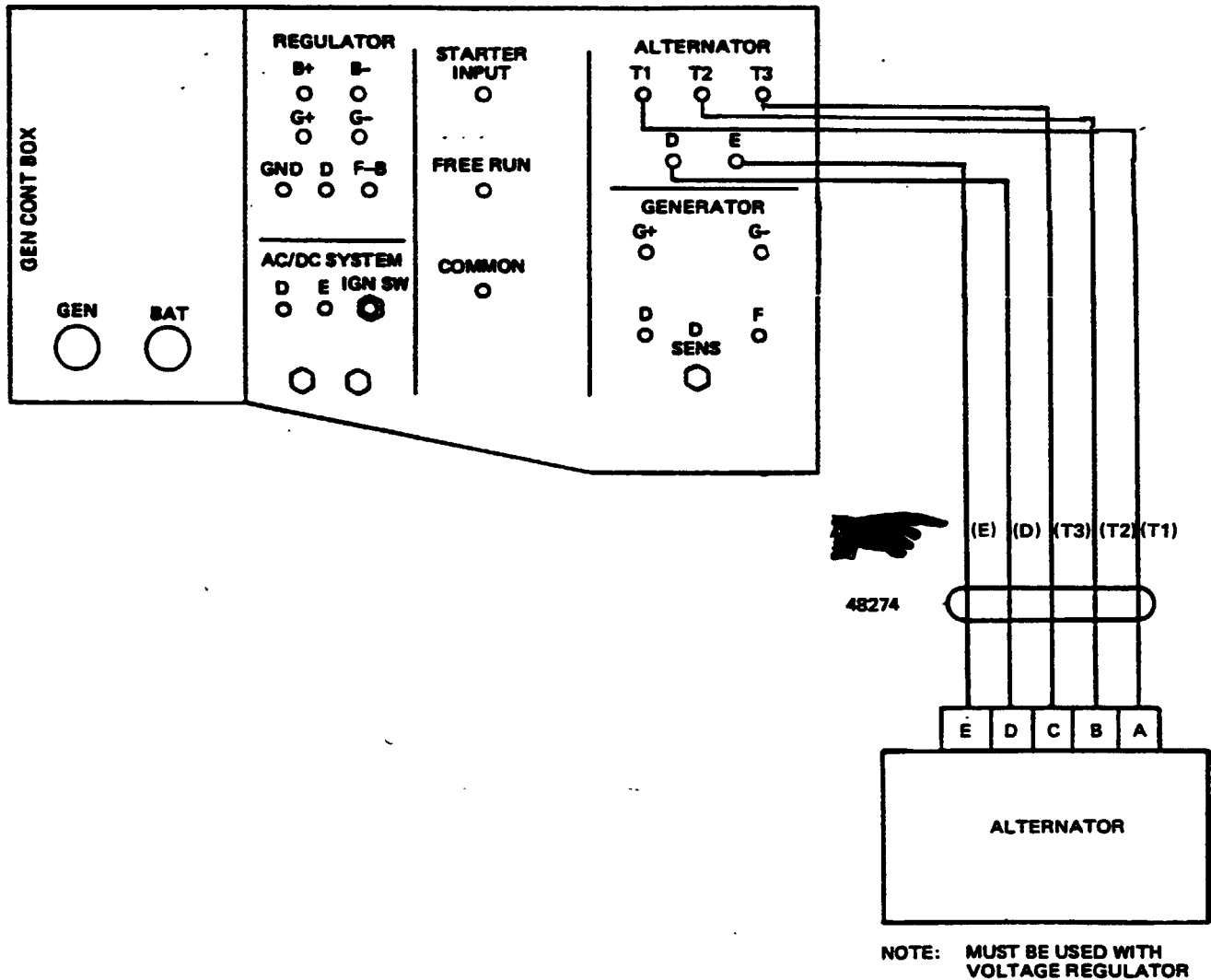

Figure 2-26. Alternator connection, 100 ampere, 28 vdc (Army P/N 10947517, Leece Neville A001-2184-AC; Army P/N 10947517, Leece Neville A001-2152-AC).

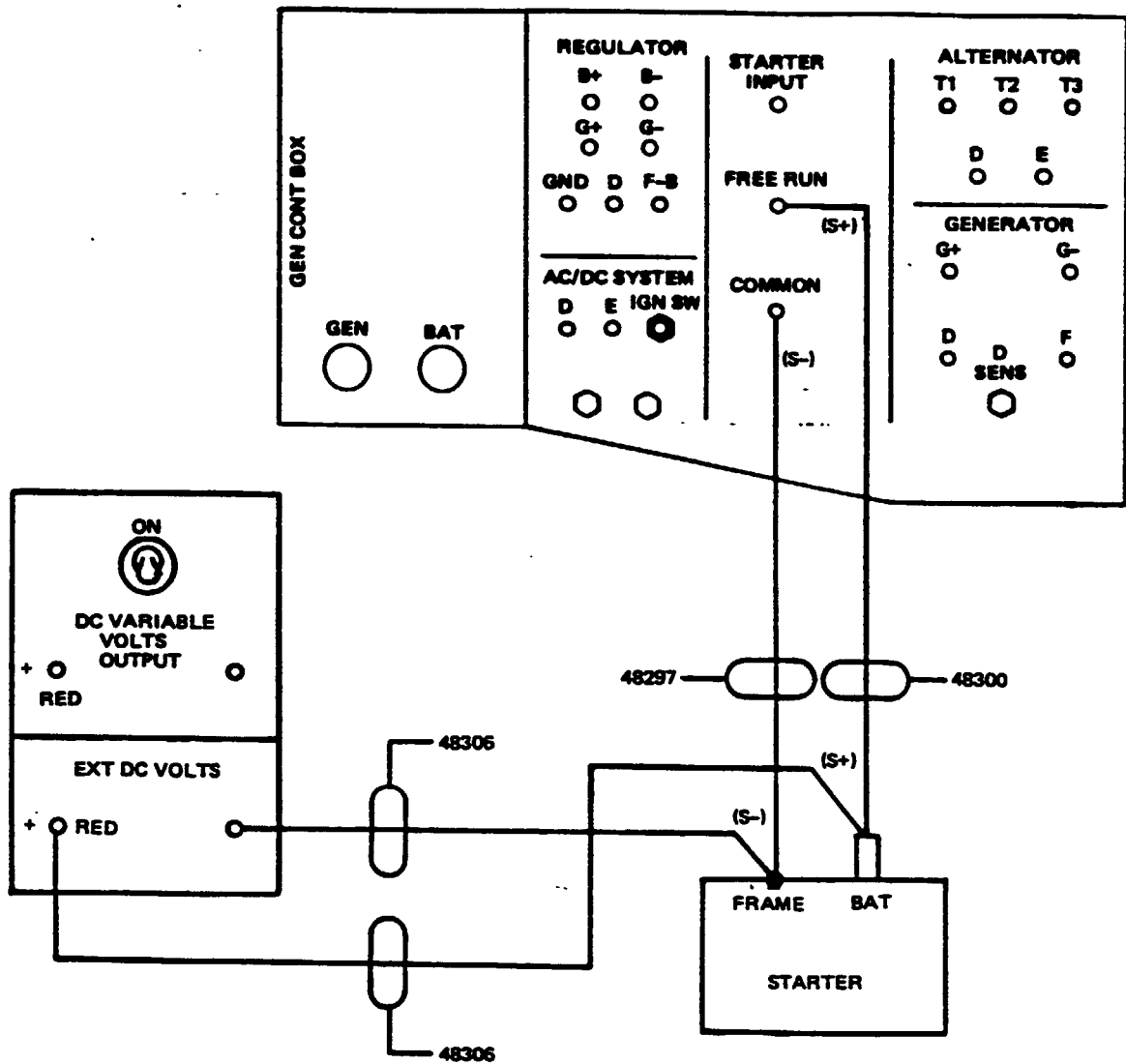

Figure 2-27. Starter connection, heavy duty (Army P/N 7386254, Bendix EC-3615-1; Army P/N 7539438, Bendix EC-1416-29F; Army P/N 7998649, Lear Siegler 20074-000; Army P/N 7018076, Lear Siegler D42-1-0; Army P/N 7539438, Lear Siegler D42-1-0).

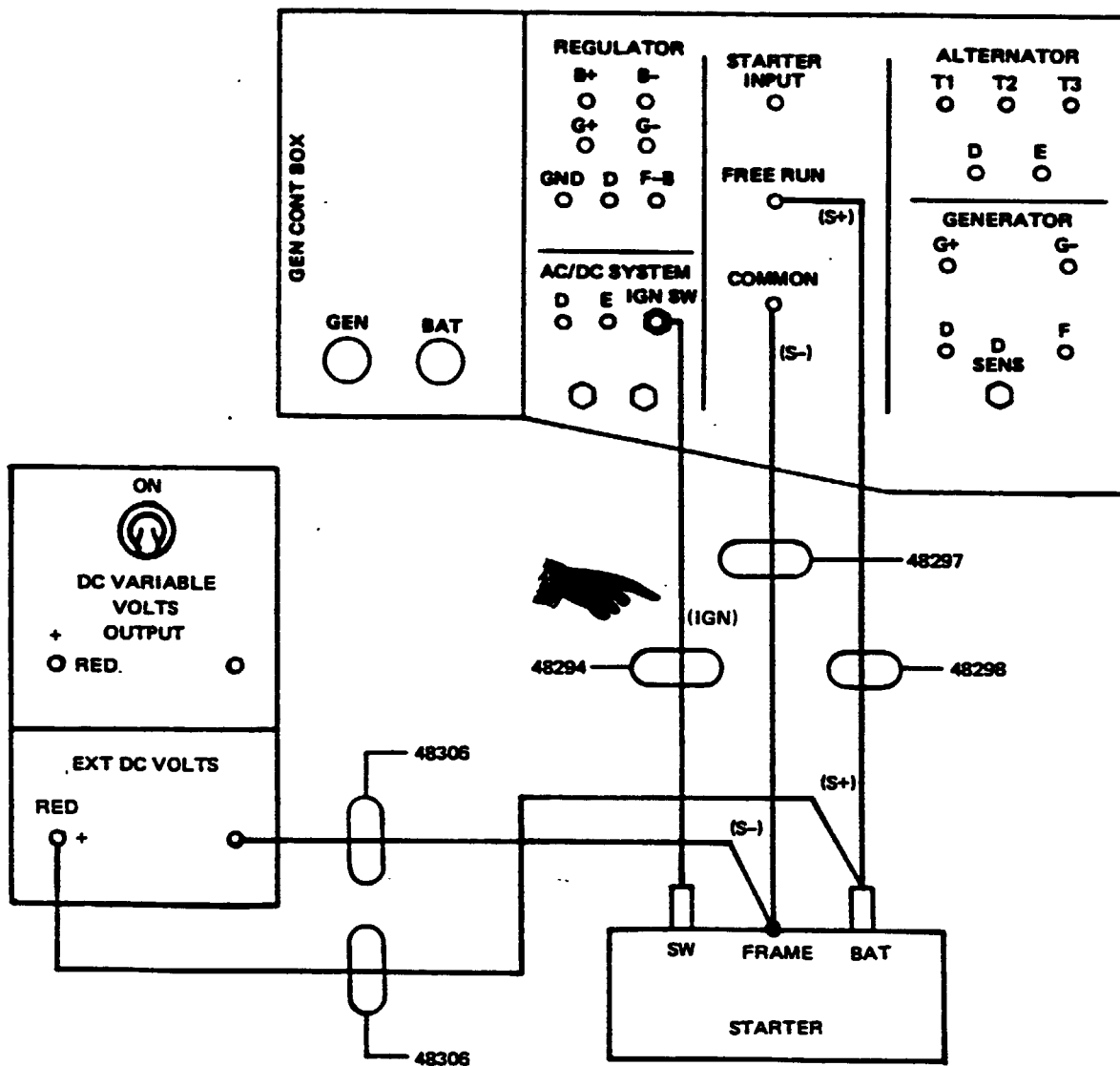

Figure 2-28. Starter connection (Army P/N 10935376, Leece Neville 7072MC; Army P/N 10911018, Delco Remy 1113943; Army P/N 10947131, Delco Remy 1113940; Army P/N 8737705, Delco Remy 1108259; Army P/N 7762618, Delco Remy 1108575; Army P/N 7731426, Delco Remy 1109972; Army P/N 7389561, Delco Remy 1108898; Army P/N 7402334, Delco Remy 1113944; Delco Remy 1113847; Army P/N 10943753, Prestolite MCZ-4111T; Army P/N 10951385-1, Prestolite MFY-6101-1UT; Army P/N 10951385-2, Prestolite MFY-6101-KUT; Army P/N 8712479, Prestolite AL-MEK-6001-AT).

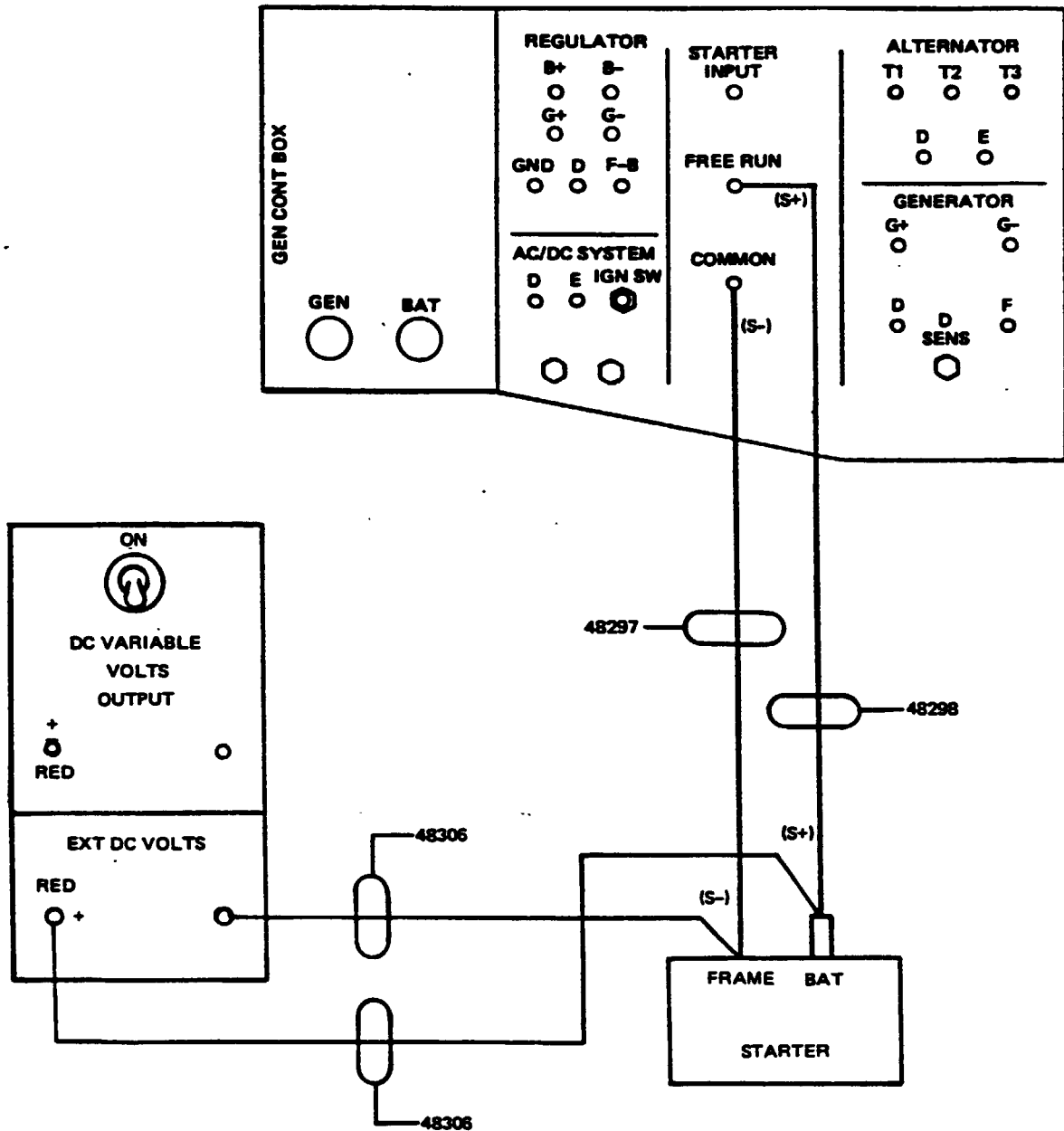

Figure 2-29. Starter connection (Delco Remy 1109045; Army P/N 10951134, Prestolite MBC-4044-UT; Army P/N 7355783, Prestolite AL-MCZ-4002-UT; Army P/N 10945002, Prestolite MDZ-4001-UT; Army P/N 7355782, Prestolite MCZ-4001-UT).

Section II. PREVENTIVE MAINTENANCE CHECKS AND SERVICES

2-10. GENERAL

a. Before you operate. Always keep in mind the CAUTIONS and WARNINGS. Perform your before PMCS.

b. Check meters for cracked or broken glass and bent or broken pointers.

c. Check switches for binding and damage.

d. Check knobs for chips, cracks, and see that they are secure on shafts.

e. Check lamps to see that they operate as specified in operating instructions.

f. Check to make sure that ground strap is secure.

g. While you operate. Always keep in mind the CAUTIONS AND WARNINGS.

h. If your equipment fails to operate. Report any deficiencies using the proper forms, see DA PAM 738-750.

2-11. PMCS PROCEDURES. Operator preventive maintenance checks and services are listed in table 2-2. Checks and services are numbered in the table in chronological order regardless of interval. The item number column of the table shall be used as a source of item numbers for the "TM Number" column on DA Form 2404, Equipment Inspection and Maintenance Worksheet, in recording results of PMCS.

2-12. CLEANING

WARNING

Provide adequate ventilation both during and after use of trichloroethane. Avoid prolonged inhalation of vapor. Wear rubber gloves.

WARNING

Self-emulsifying decreasing solvent compound and dry-cleaning solvent are flammable and should not be used near open flame. Keep fire extinguishers handy when using these materials. Use only in well ventilated places. Wear rubber gloves when using these materials.

WARNING

The use of diesel fuel oil, gasoline, or benzine (benzol) for cleaning is prohibited.

CAUTION

Avoid getting petroleum products, such as dry cleaning solvent, engine fuels, or lubricants on rubber parts, as they will deteriorate the rubber.

a. General. Any special cleaning instructions required for specific components or parts are contained in the pertinent section. General cleaning instructions are as outlined in (1) through (4) below.

(1) Metal parts.

(a) Use clean water or a solution of 1/4 pound of soap chips to 1 gallon of hot water for all parts and for overall general cleaning of painted surfaces.

(b) After parts are clean, dry them thoroughly. Apply a light film of lubricating oil preservative, medium (MIL-L-3150) to all parts having a polished surface to prevent rusting.

(c) Before installing new parts, remove any rust-preventing compound, protective grease, etc. Prepare as required (oil seals, etc.). For those parts requiring lubrication, apply the lubricant prescribed in the lubrication chart (fig 3-1).

(2) Electrical parts. Use technical trichloroethane (methyl chloroform), specification O-T-620, for cleaning. Clean painted parts and plastics by wiping, brushing, or spraying but never immersing or soaking in trichloroethane. Do not use trichloroethane to clean leather or rubber parts (other than neoprene).

(3) Rubber parts other than electrical. Clean rubber parts with soap and warm water. Apply a coating of powdered talcum (specification U-T-30) to preserve the rubber.

(4) Meters. Clean each meter glass using a soft cloth dampened with a solution of common detergent and water. After cleaning, allow to dry without rubbing.

b. Rust Removal. Remove rust or corrosion from all parts of the test stand. To remove rust or corrosion from unfinished surfaces, use steel cleaning brushes or abrasive cloth. On finished surfaces other than highly polished surfaces, remove rust or corrosion by buffing with a rotary wire brush constructed of steel wire between 0.010 and 0.025 inch in diameter. Crocus cloth may be used manually to remove rust or corrosion from polished surfaces.

c. Paint Touch-up. To touch up painted enclosure surfaces, use primer, specification TT-P-664, followed by enamel paint, alkyd gloss, specification TT-E-489, class B, machinery gray color per ANSI 255.1, color chip number 70.

Table 2-2. Operator's Preventive Maintenance Checks and Services

NOTE: a. Perform weekly as well as before operation PMCS if:

- (1) You are the assigned operator and have not operated the item since the last weekly.
- (2) You are operating the item for the first time.

b. Within designated interval, these checks are to be performed in the order listed.

B-Before

A-After

D-During

| Item No. | Interval B D A | Item to be Inspected | Procedures | Equipment will be Reported NOT READY (Red) if: |
|----------|-------------------|------------------------------|---|--|
| 1 | X X | Instrument Panel Meters | Check for incorrect zeroing and pointer sticks or operates erratically. | Any meter defect is noted. |
| 2 | X | <u>Varidrive</u> Gearcase | Check gear case oil level. Should be within 3/4 inch from top of sight gage. Add oil as needed. | |
| 3 | X | Air vents | Inspect air exhaust vent for obstructions. Remove obstructions. | |
| 4 | X | Hardware | Check for loose mounting hardware. Tighten as required. | |
| 5 | X | Accessories | Check harness assemblies for damaged insulation or connectors. | |
| 6 | X | Lamps | Check for illumination. | |

Section III. OPERATION OF AUXILIARY EQUIPMENT

Not Applicable.

Section IV. OPERATION UNDER UNUSUAL CONDITIONS

2-13. OPERATION IN EXTREME COLD WEATHER CONDITIONS

a. General. Other than as specified below, operation under extreme cold weather conditions will be the same as under usual conditions. If possible, house the test stand (van mounted) inside a heated enclosure when not in use to assure easy starting and to minimize adverse effects of extreme cold weather conditions.

WARNING

Do not attempt to charge frozen batteries.

b. Batteries. Check the batteries for freezing, which will prevent them from furnishing sufficient current, and may cause electrical short circuits. Frozen batteries may possibly explode, causing bodily harm.

c. Lubrication. Lubrication of the test stand is to be performed in accordance with the prevailing temperatures, as prescribed in the lubrication section (Chapter 3, Section I).

d. Starting. Allow the drive motor to run for at least 15 minutes at approximately 1000 rpm to warm up completely before starting any tests.

2-14. OPERATING IN EXTREME HOT WEATHER CONDITIONS

a. General. Station the test stand so that it is protected from the direct rays of the sun during operation. Keep the air intake and air exhaust free from obstructions which may hamper proper ventilation. Be alert during operation for unusual odors, smoke, peculiar noise, or other indications of an overheated drive motor or blower motor.

b. Lubrication. Lubrication of the test stand is to be performed in accordance with prevailing temperatures, as prescribed in the lubrication section (Chapter 3, Section I).

2-15. OPERATION IN HIGH HUMIDITY. Start the test stand and let it run at approximately 1000 rpm for 15 minutes to allow circulating air within the cabinet to dissipate accumulated condensation. When moving the test stand from a low temperature area to a high temperature area, keep the test stand covered, if possible, with a waterproof cover until it warms to the ambient temperature to minimize condensation.

CHAPTER 3

OPERATOR/CREW MAINTENANCE INSTRUCTIONS

Section I. LUBRICATION

3-1. CONSUMABLE SUPPLIES AND MATERIALS. Consumable supplies and materials used for cleaning, lubricating, and maintenance of the test stand are listed in table 3-1.

Table 3-1. Consumable Supplies and Materials

| NSN | Quantity | Description |
|------------------|----------|----------------------|
| 9150-00-189-6727 | 1 qt. | SAE No. 10 |
| 9150-00-068-9475 | 1 qt. | SAE No. 20 |
| 9150-00-262-7617 | 1 qt. | SAE No. 30 |
| 9150-00-754-2595 | 1 lb. | Molybdenum Disulfide |

CAUTION

The varidrive gear case is shipped without oil. Be certain to keep gear case filled to proper level.

3-2. LUBRICATION CHART. The lubrication chart (fig 3-1) prescribes test stand procedures as to operational time, locations, intervals, and proper materials.

3-3. GENERAL LUBRICATION INSTRUCTIONS

a. Usual Conditions. Lubrication intervals specified in the lubrication chart are for normal operation where moderate temperature and humidity prevail.

b. Lubrication Equipment. Clean lubrication equipment before and after use. Operate lubricating guns carefully in such a manner as to ensure proper-distribution of lubricant.

c. Points of Application. Lubrication fittings, oilers, and the oil filler tube are keyed to the lubrication chart (fig 3-1). Wipe these devices and surrounding surfaces before applying-the lubricant. Lubricate the various points as described below:

(1) Gear case.

(a) Change oil after first week service and twice yearly thereafter.

(b) Use oil as listed on figure 3-1. If not available, use an equivalent SAE motor oil.

(2) Varidrive (Part No. 7458-2).

(a) Lubricate the varidrive in accordance with figure 3-1.

(b) Bearings of the varidrive must be flushed as follows:

1. Remove bearing drain plugs from bracket and bracket support.

NOTE

Tachometer generator housing (6, fig 3-1) must be removed to gain access to the rear bearing drain plug.

2. Apply lubricant to grease fitting of bracket and bracket support with pressure gun until all old lubricant is forced out of the drain.

3. Operate varidrive for five minutes and then install bearing drain plugs.

(3) Varidrive (Part No. 7458-4).

(a) Lubricate the varidrive in accordance with figure 3-2.

(b) After the first week of operation:

1. Disconnect main power from the test stand.

2. Remove the oil fill pipe plug located at the top center of the varidrive gearcase.

3. Remove the oil drain pipe plug located at the bottom of the oil sight gage, and drain the oil from the varidrive gearcase.

4. Install the oil drain pipe plug at the bottom of the oil sight gage.

5. Remove the oil level plug located on the lower left side of the varidrive gearcase.

6. Fill the varidrive gearcase through the oil fill plug opening with the specified oil, until the oil begins to drip from the oil level plug opening.

7. Install the oil level plug and the oil fill plug. Wipe away all oil drips.

(c) Twice yearly, change the varidrive gearcase oil, using the same procedure as in step (b) above.

(d) Lubricate the motor adjust disc and motor front bearings as follows:

1. Disconnect main power from the test stand.
2. Add two ounces of grease through each of lubrication fittings P3 and P4 at the lower front edge of the drive control panel.

(e) Lubricate the input shaft rear bearing and motor rear bearing as follows:

1. Disconnect main power from the test stand.
2. Remove bearing drain plugs from fittings D1 and D2 at the lower-front edge of the drive control panel.
3. Using a pressure grease gun, add lubricant to fittings P1 and P2 at the lower front edge of the drive control panel until lubricant is forced out through fittings D1 and D2.
4. Turn on main power to the test stand and operate the varidrive for 5 minutes. Then, disconnect main power from the test stand and install bearing drain plugs in fittings D1 and D2.

(4) Splined coupling (5, fig 2-9) and adapter spline (6, fig 2-9). Using a small amount of molybdenum disulfide grease, lightly coat all internal and external splines.

(5) Generator mounting bracket located on the right hand corner of test stand. Coat the shaft of the generator slide bracket shaft with a light oil (SAE No. 10).

(6) Metal parts. Apply a light coat of light oil (SAE No. 10) to all metal parts not protected against rust of mating surfaces.

d. Reports and Records. Report unsatisfactory performance of material or effect of prescribed lubricants and preserving materials, using SF Form 368, Quality Deficiency Report.

3-4. LUBRICATION UNDER UNUSUAL CONDITIONS.

a. Unusual Conditions. Reduce lubrication intervals specified on the lubrication chart to compensate for abnormal operation and extreme conditions, such as high or low temperatures, prolonged periods of high speed operation, continued operation in sand or dust, or exposure to moisture, any one of which may quickly destroy the protective quality of the lubricant. Lubrication intervals may be extended during inactive periods.

b. Special Conditions. Lubricate spring loaded arm of regulator mounting plate assembly with a general purpose lubricating oil once a

month. Use preservative P-9 oil on all unpainted surfaces of ferrous parts such as pulleys, pulley adapter, etc., on a monthly basis.

c. Changing Grades of Lubricants. Lubricants are prescribed in figure 3-1 in accordance with two temperature ranges: from +25° to +65°F and from 50° to 110°F. When to-change grade of lubricants is determined by maintaining a close check on operation of the test stand during the approach to changeover periods in accordance with weather forecast data. Ordinarily, it will be necessary to change grade of lubricants only when air temperatures are consistently in the next higher or next lower range.

Section II. TROUBLESHOOTING

3-5 GENERAL

a. This section contains troubleshooting information for locating troubles which may develop in the test stand. Each malfunction for an individual component is followed by a list of tests or inspections which will help you to determine the corrective actions for you to take. . You should perform the tests/inspections and corrective actions in the order listed.

b. This manual cannot list all possible malfunctions that may occur, nor all tests or inspections and corrective actions. If a malfunction is not listed (except when malfunction and cause are obvious) or is not corrected by listed corrective actions, notify your supervisor.

3-6. TROUBLESHOOTING TABLE. Table 3-2 contains troubleshooting instructions for operator.

WARNING

High voltages that are dangerous to life are used in the test stand. Avoid contact with conducting parts. Turn off input power whenever possible before connecting or disconnecting test equipment.

WARNING

The test stand contains rapidly rotating parts. Make certain that all parts that rotate are securely attached before operating the test stand.

WARNING

The noise level during operation of the test stand is high. To protect hearing, wear an acoustical ear muff.

CAUTION

Never connect an ohmmeter across the calibration binding posts for the front panel meters. Some of the meters have millivolt movements that may be damaged by ohmmeter output voltage.

Section III. MAINTENANCE

3-7. OPERATOR MAINTENANCE. Maintenance of the test stand at the operator maintenance level is limited to inspection, test, service and replacing defective indicator lamps and knobs. Unscrew the torpedo lens and check the indicator lamp for defective filament. Replace defective lamps.

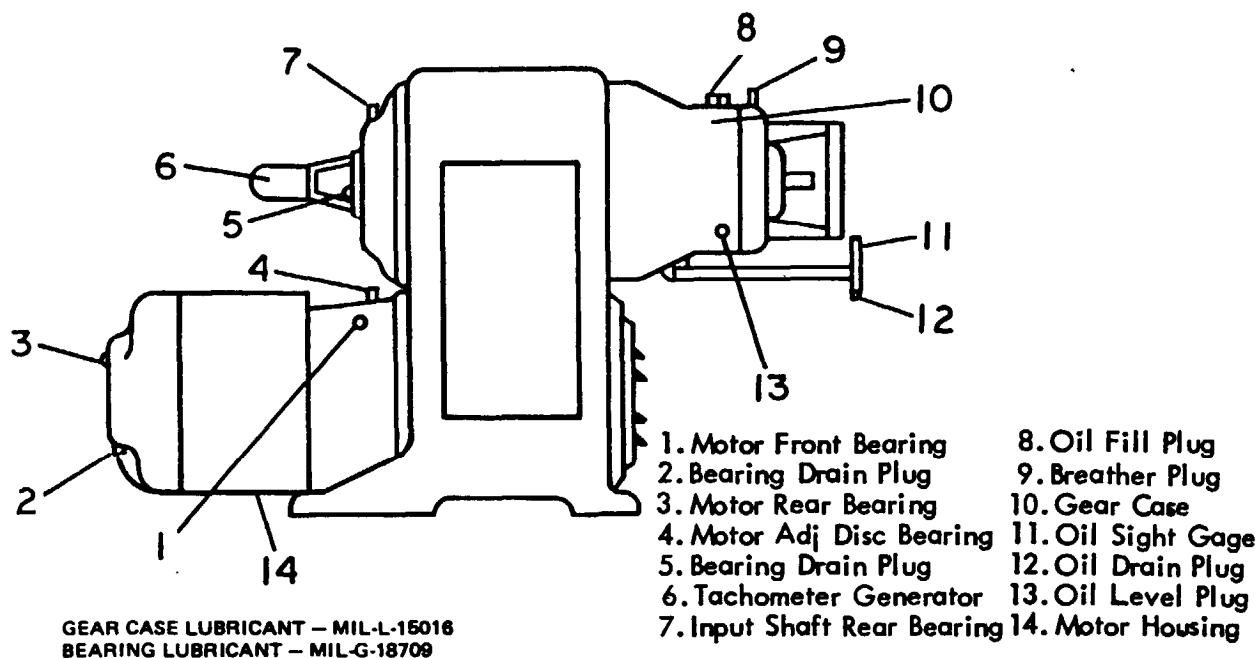

| VARIDRIVE GEAR CASE | | | | |
|---------------------|--------------|----------------------|-------------|----------------------|
| OPERATIONAL TIME | OPER TEMP °F | VISCOSITY S.U.V. SEC | APP SAE NO. | LUBRICATION INTERVAL |
| 8 HR/DAY | 25 - 65 | 300 - 400 @ 100°F | 20 | CHANGE YEARLY |
| | 50 - 110 | 500 - 650 @ 100°F | 30 | |
| CONTINUOUS | 25 - 65 | 300 - 400 @ 100°F | 20 | CHANGE SEMI ANNUALLY |
| | 50 - 110 | 500 - 650 @ 100°F | 30 | |

NOTE - CHANGE VARIDRIVE OIL AFTER FIRST WEEK OF SERVICE

| VARIDRIVE BEARINGS | | | |
|--------------------|----------------------|----------|-----------------|
| OPERATING TIME | LUBRICATION INTERVAL | LOCATION | REMARKS |
| 8 HR/DAY | MONTHLY | 3 & 4 | ADD 2 OZ GREASE |
| | SEMI ANNUALLY | 3 & 4 | ADD 2 OZ GREASE |
| CONTINUOUS | 2 WEEKS | 1 & 5 | LUBRIFLUSH |
| | QUARTERLY | 1 & 5 | LUBRIFLUSH |

Figure 3-1. Varidrive lubrication chart (part number 7458-2)



GEAR CASE LUBRICANT – MIL-L-15016
 BEARING LUBRICANT – MIL-G-18709

| VARIDRIVE GEAR CASE | | | | |
|---------------------|--------------|----------------------|-------------|----------------------|
| OPERATIONAL TIME | OPER TEMP °F | VISCOSITY S.U.V. SEC | APP SAE NO. | LUBRICATION INTERVAL |
| 8 HR/DAY | 25 – 65 | 300 – 400 @ 100°F | 20 | CHANGE YEARLY |
| | 50 – 110 | 500 – 650 @ 100°F | 30 | |
| CONTINUOUS | 25 – 65 | 300 – 400 @ 100°F | 20 | CHANGE SEMI ANNUALLY |
| | 50 – 110 | 500 – 650 @ 100°F | 30 | |

NOTE – CHANGE VARIDRIVE OIL AFTER FIRST WEEK OF SERVICE

VARIDRIVE BEARINGS

| OPERATING TIME | LUBRICATION INTERVAL | LOCATION | REMARKS |
|----------------|----------------------|----------|-----------------|
| 8 HR/DAY | MONTHLY | 3 & 4 | ADD 2 OZ GREASE |
| | SEMI ANNUALLY | 3 & 4 | ADD 2 OZ GREASE |
| CONTINUOUS | 2 WEEKS | 1 & 5 | LUBRIFLUSH |
| | QUARTERLY | 1 & 5 | LUBRIFLUSH |

Figure 3-2. Varidrive lubrication chart (part number 7458-4).

Table 3-2. Troubleshooting

MALFUNCTION

TEST OR INSPECTION
CORRECTIVE ACTION

TEST STAND

1. TEST STAND FAILS TO OPERATE.

Step 1. Check to see that circuit breaker CB1 (fig 2-5) is set to ON.
Set circuit breaker CB1 to ON.

Step 2. Check for open high voltage compartment access door (5, fig 4-3).
Close high voltage compartment access door.

Step 3. Check for obstructed air intake and air exhaust vents, located on the top left side of test stand.
Remove obstruction.

Step 4. Turn off external power switch and check external power source connections.
Tighten loose power connections.

Step 5. Notify higher maintenance.

2. INCORRECT METER READING NOTED DURING OPERATION

Step 1. Check for incorrect control settings (table 2-1).
Set all operating controls to specified settings.

Step 2. Check meter for incorrect zeroing.
With test stand switched off, zero meters.

Step 3. Notify higher maintenance.

CHAPTER 4
ORGANIZATIONAL MAINTENANCE INSTRUCTIONS

Section I. SERVICE UPON RECEIPT

4-1. UNPACKING AND INSPECTION

- a. Uncrate the test stand and set it on a solid, level floor or foundation, using a suitable fork-lift through the locations provided (fig 4-1).
- b. Remove all barrier material from the test stand.
- c. Inspect the test stand for damage to the motor housing (14, fig 3-1) of the varidrive, the gearcase (10, fig 3-1) of the varidrive, the blower housing and mounting (4, fig 4-4), the blower duct, and all front panel meters and switches (fig 2-1 and 2-2).
- d. Check to see that all interconnecting cables are in good condition, and that all wiring is undamaged and secure.

NOTE

All accessories are shipped in the storage compartment (3, fig 4-4) or the rectifier chamber (6, fig 4-3) and battery compartment (4, fig 4-3).

- e. Inspect and tighten, as necessary, all screws, bolts, knobs, and terminals.
- f. Check the zero setting of all meters (see 2-3.c).

4-2. INSTALLATION.

a. Power Requirements. A 230/460 volt, 3 phase, 60 Hz, ac power source is required for operation of the test stand. The test stand can be operated from a diesel-generator source of power, providing that the input to the test stand is regulated and maintained at 230/460 volts, 60 Hz. Note the following:

(1) The low voltage starting condition associated with a diesel-engine generator is compensated for by using a low voltage coil for starting with a voltage dropping resistor in series with the coil for running conditions.

(2) If the nominal output voltage of the diesel-engine generator is lower than 230/460 volts, the power delivered by the output shafts will be reduced as shown in table 4-1.

b. Installation Site. Insure that the site for the test stand is dry, free from moisture drips, and not exposed to dirt. The selected site should be in a cool, ventilated location that is not subject to heat and is free from hazardous processes. Outline dimensions of the test stand are shown in figure 4-1.

c. Installation Procedure.

(1) Using a fork-lift completely through the locations provided (fig 4-1) set the test stand into position. Vibration dampening material between the machine and floor and hold down bolts are recommended.

(2) Using flexible grounding straps, ground the base assembly of the test stand to a substantial ground.

(3) Lubricate the gearcase of the varidrive. (Refer to fig 3-1.)

CAUTION

The gearcase is emptied before shipment and must be filled before the test stand is placed in service.

(4) The test stand is shipped connected for 230 volt, 3 phase, 60 Hz operation. For conversion for 460 volt operation, rearrange links as shown in figure 4-2.

WARNING

Make certain that circuit breaker switch CB1 in the high voltage (fig 2-5) compartment is set to the OFF position before touching any internal electrical connections.

(5) Insert the proper heater elements (fig 4-2) in the starter. On part number 7458-2, use heater element CR 123 F 91.4B for 230 volt operation, and use heater element CR 123 F48.7B for 460 volt operation. On part number 7458-4, use heater element AH42430 for 230 volt operation, and use heater element AH42232 for 460 volt operation.

Table 4-1. Power Requirements Chart

| Condition | Speed | KVA at 230/460 volts |
|----------------------|--------------|----------------------|
| Starting | Locked rotor | 166.0 |
| 35 HP (intermittent) | 1000 RPM | 37.1 |
| | 9000 RPM | 39.3 |
| 22 HP (continuous) | 1000 RPM | 24.9 |
| | 9000 RPM | 26.4 |

NOTES:

1. To determine input current requirement, use following formula:

$$I_{\text{(Amps)}} = \frac{\text{KVA}}{1.73 \times V_{\text{(line)}}}$$

2. When the test stand is connected to a power source of less than 230/460 volts, the continuous duty rating remains at rated HP, provided that the voltage reduction is not more than 10%; however, the intermittent duty overload rating should be reduced in direct proportion to the square of percent reduced voltage to nominal voltage.

For example:

Nominal voltage - 230

Reduced voltage = 205

$205/230 = 0.8913$

$0.8913^2 = 0.7944$

New intermittent duty rating = $HP_{\text{(nominal)}} \times 0.7944$

$35 \text{ HP} \times 0.7944 = 27.8 \text{ HP}$

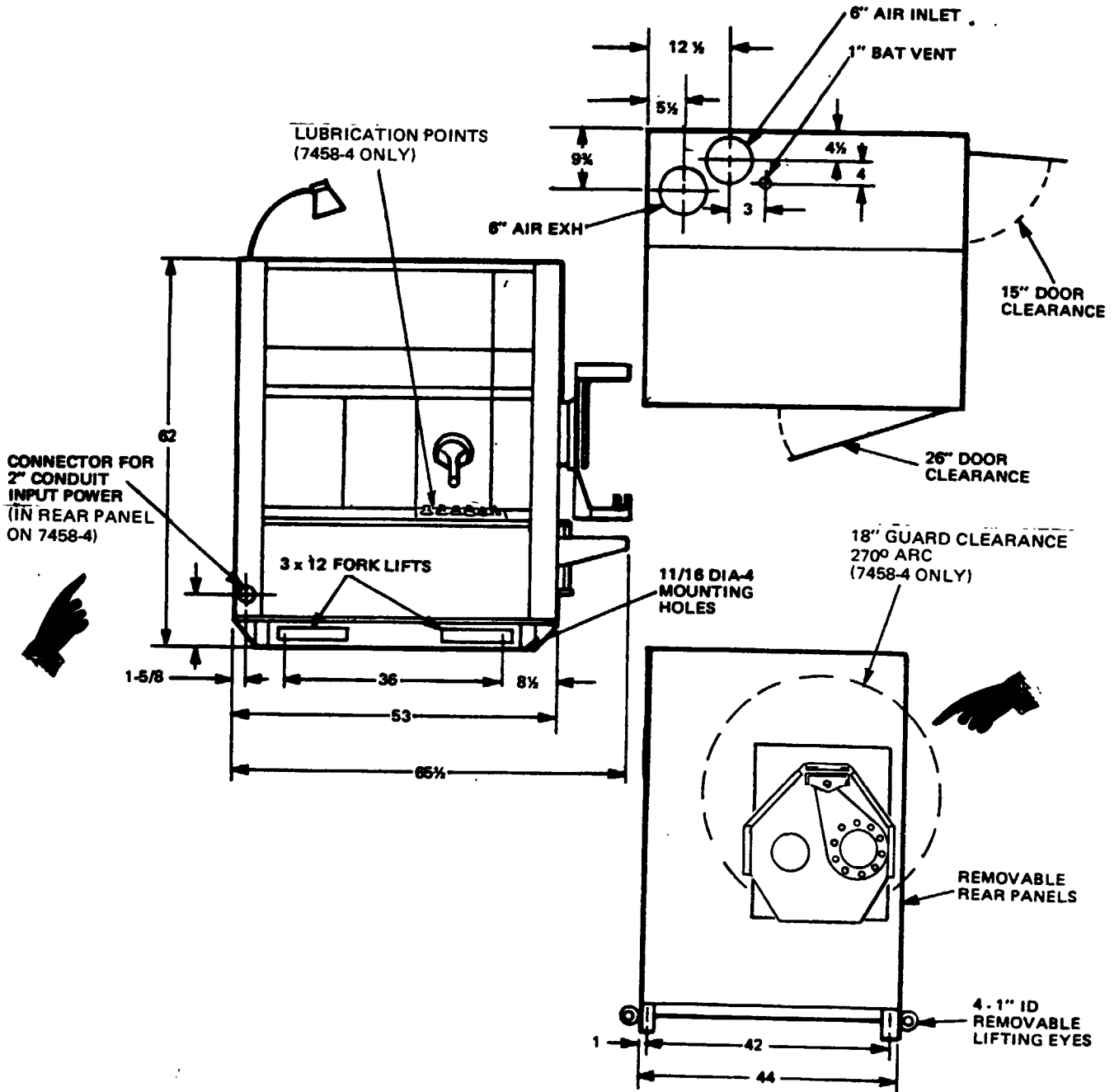
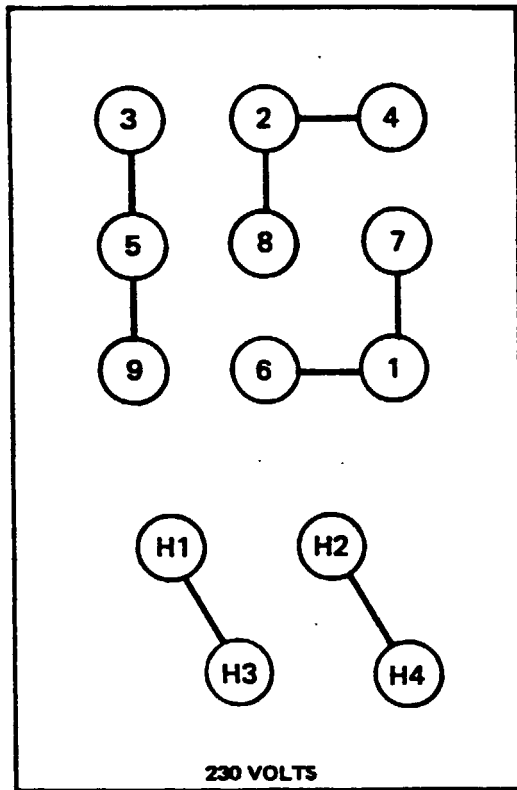

Figure 4-1. Test stand outline dimensions.



230 VOLTS

TERMINAL BOARD

| PART NO. | VOLTAGE | HEATER ELEMENT |
|----------|---------|----------------|
| 7458-2 | 230V | GE CR123F91.4B |
| | 460V | GE CR123F48.7B |
| 7458-4 | 230V | AH 42430 |
| | 460V | AH 42232 |

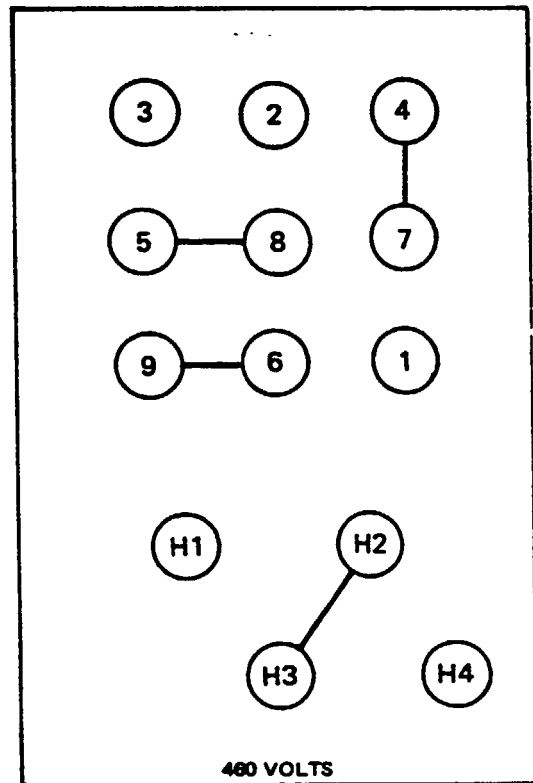

460 VOLTS

Figure 4-2. Power terminal board voltage connections.

(6) On part number 7458-2, the power service entrance is located on the left side of the test stand. On part number 7458-4, an input power conduit connector is provided at the lower rear section of the test stand. Install the input power leads and connect the leads to the input terminals of circuit breaker switch (CB1, fig 2-5) in the high voltage compartment (5, fig 4-3)

WARNING

Observe all high voltage precautions when making power connections.

(7) Attach suitable outlet pipes to the air exhaust and air intake, and to the battery vent located on the top left side of test stand. The air exhaust will accept a 6-inch external diameter pipe; the air inlet will accept a 6-inch internal diameter pipe. If air exhaust and air intake pipes are not attached properly, the airflow interlock switch will prevent test stand operation. All external ducting is to be made with 6-inch round smooth ducting and elbows. Keep all external ducting to a minimum length.

4-3. CHECKOUT. Apply power to the test stand and check to see that it operates. The direction of drive motor rotation is not important; a reversing switch is provided for reversing drive motor rotation as necessary. With an input A-B-C phase rotation, setting reversing switch (S1, fig 2-5) to the down position will cause clockwise rotation of the output shafts, as viewed facing the output shafts.

4-4. CALIBRATION. Calibrate the front panel meters in accordance with TB 9-4910-527-50, Calibration Procedure for Generator and Starter Test Stand, United Manufacturing Models 7458, 7336, and Sun Electric Model AGT-9.

Section II. LUBRICATION INSTRUCTIONS

4-5. GENERAL. All test stand lubrication is performed at the operator maintenance level. Lubrication instructions are contained in Chapter 3, Section I.

Section III. PREVENTIVE MAINTENANCE CHECKS AND SERVICES

4-6. GENERAL. Refer to table 2-2. These instructions apply equally at the organizational maintenance level.

4-7. MAINTENANCE. Except for replacement of indicator lamps, knobs, and accessories items, organizational maintenance is limited to inspection, test, and service, and partial disassembly of the test stand required to gain access to parts for performance of these actions. Refer to all other maintenance to direct and general support maintenance personnel.

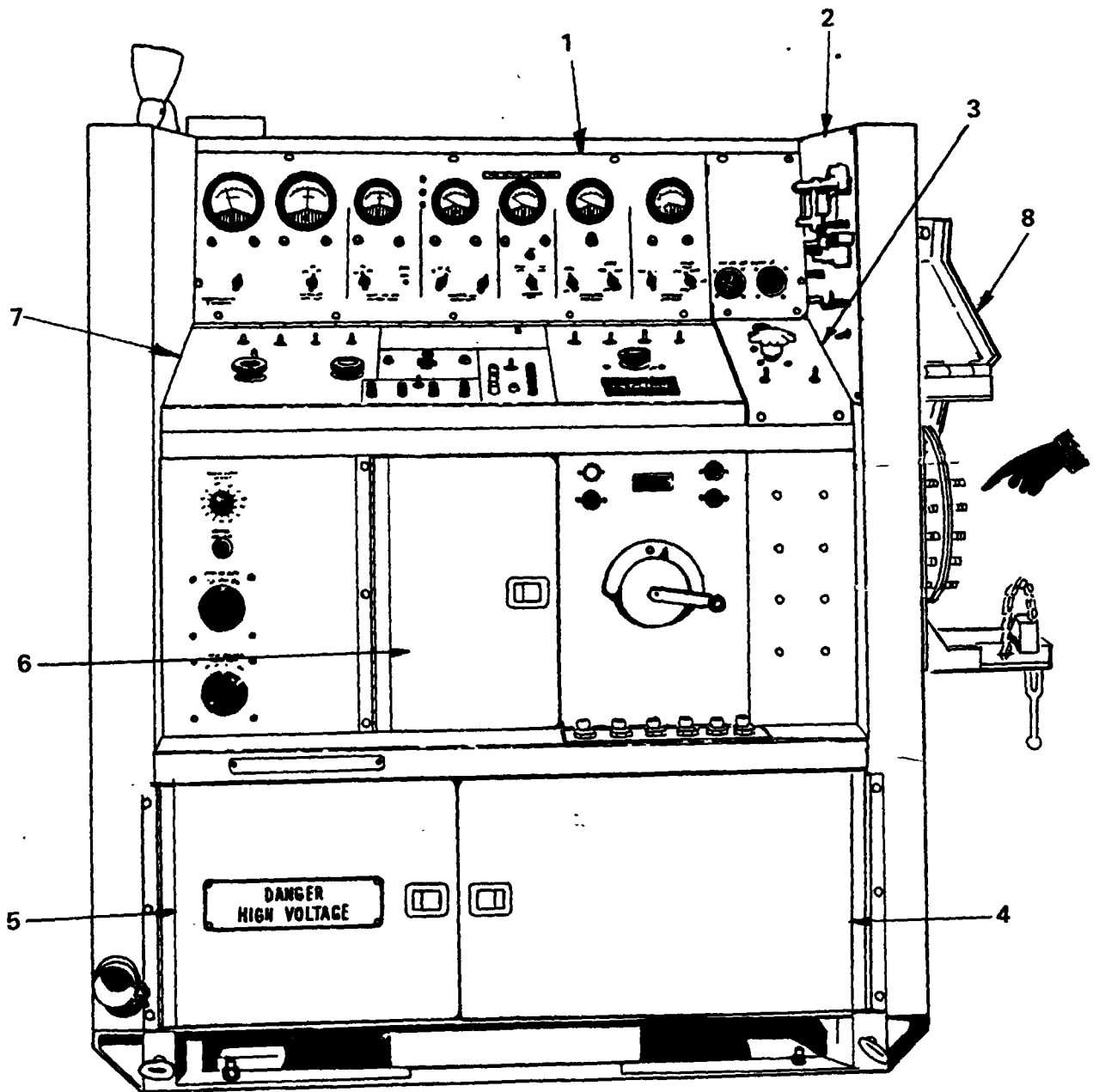

Legend for fig 4-3:

- 1. Instrument panel assembly
- 2. Binding post panel assembly
- 3. Rheostat panel assembly
- 4. Battery compartment
- 5. High voltage compartment
- 6. Rectifier chamber assembly
- 7. Control panel assembly
- 8. Belt guard (part number 7458-4 only)

Figure 4-3. Test stand, front view, major assemblies

4-8. INSTRUMENT PANEL ASSEMBLY (1, fig 4-3)

a. Disassembly

(1) Disconnect main power source.

(2) Remove screws that attach instrument panel assembly to test stand and lower instrument panel assembly.

b. Inspection.

(1) Check to see that meter connections are secure.

(2) Check to see that cable insulation is not hard, brittle, spongy, oil soaked, cracked, frayed, or otherwise deteriorated.

(3) Inspect switches for visual damage and for loose wires.

c. Assembly.

(1) Raise instrument panel assembly into position and attach instrument panel assembly to test stand with screws.

(2) Refer to direct support for replacement.

(3) Inspect knobs for damage. Replace damaged knobs.

4-9. CONTROL PANEL ASSEMBLY (7, fig 4-3)

a. Disassembly.

(1) Disconnect main power source.

(2) Remove screws that attach control panel assembly to test stand.

(3) Raise control panel assembly and secure with the bolt slide located on top of the left side of test stand.

b. Inspection.

(1) Check to see that all cable connections are secure.

(2) Check to see that cable insulation is not hard, brittle, spongy, oil soaked, cracked, frayed, or otherwise deteriorated.

(3) Inspect rotary switches and rheostats for damaged contact points.

c. Assembly.

(1) Disengage control panel assembly lock and lower control panel assembly.

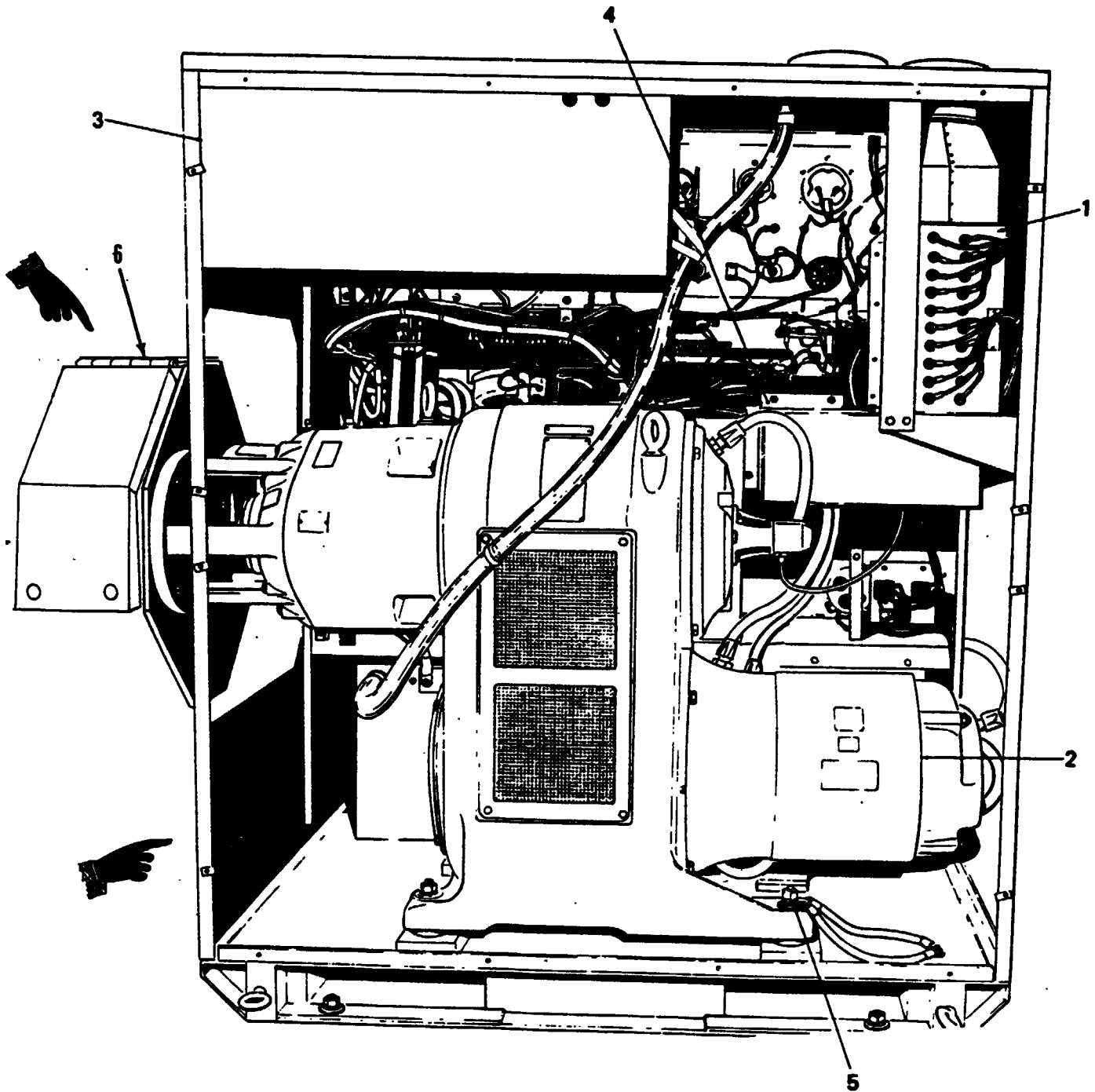

Legend for fig 4-4:

1. Load bank assembly
2. Varidrive
3. Storage compartment
4. Blower assembly
5. Ground strap
6. Belt guard (part number 7458-4 only)

Figure 4-4. Test stand, rear view, major assemblies.

(2) Secure control panel assembly with screws.

(3) Inspect knobs for damage.

(4) Inspect terminals for damage.

4-10. VARIDRIVE ASSEMBLY (2, fig 4-4).

a. Disassembly.

(1) Disconnect main power source.

(2) Remove screws that secure two cabinet rear covers and remove covers.

b. Inspection.

(1) Check to see that ground strap (5), located at the base of the varidrive assembly, is secure.

(2) Check to see that cable insulation is not hard, brittle, spongy, oil soaked, cracked, frayed, or otherwise deteriorated.

(3) Check to see that tachometer generator (6, fig 3-1) is secure.

(4) Inspect rear panel and access cover for noticeable bulging, distortion, tears, and splits.

(5) Check to see that all accessories are secure.

(6) Check to see that all parts of oil sight gage (11, fig 3-1) are secure so as to prevent loss of lubricant.

(7) Remove varibelt cover, located on the back of the varidrive assembly.

(8) Inspect varibelt for cracking, splitting, fraying, and for stretching or wear on sides. If any of these conditions are noted, varibelt is unserviceable. Refer to direct support for replacement.

(9) On part number 7458-4, inspect grease lines and fittings for cracks, splits, fraying, or leakage. Tighten loose fittings and lines, as necessary. Refer other problems to organizational maintenance for replacement.

c. Assembly.

(1) Install varibelt cover.

(2) Install two cabinet rear covers, and secure covers with screws.

APPENDIX A

REFERENCES

| | |
|-----------------------------|---|
| AR 750-1 | Army Materiel Maintenance Concepts and Policies |
| FM 9-207 | Operation and Maintenance of Ordnance Material in Cold Weather (0° to 60°) |
| TB 9-4910-527-50 | Calibration Procedures for Generator and Starter Test Stand, United Manufacturing Model 7336 and 7458, and Sun Electric AGT-9 |
| TM 9-247 | Materials Used for Cleaning, Preserving, Abrading, and Cementing Ordnance Materiel |
| TM 9-4910-663-24P | Repair Parts List for Test Stand, Automotive, Generator, Alternator, Starter and Associated Equipment |
| TM 9-4910-663-34 | DS-GS Maintenance Manual for Automotive Generator, Alternator, Starter Test Stand and Associated Equipment |
| TM 9-6140-200-14 | Maintenance of Lead-Acid Batteries |
| TM 38-750 | The Army Maintenance Management Systems (TAMMS) |
| TM 43-0139 | Painting Instructions for Field Use |
| TM 740-90-1 | Administrative Storage of Equipment |
| TM 743-200-1 | Storage and Materials Handling |
| TM 750-244-3 | Procedures for Destruction of Equipment to Prevent Enemy Use |
| MIL-L-3150 | Lubricating Oil, Preservative Medium |
| U-T-30 | Talcum Powder |

APPENDIX B
COMPONENTS OF END ITEM LIST

Not applicable.

APPENDIX C
ADDITIONAL AUTHORIZATION LIST

Not applicable.

APPENDIX D

MAINTENANCE ALLOCATION CHART

Section I. INTRODUCTION

D-1. **PURPOSE.** The maintenance allocation chart allocates specific maintenance operations to the proper echelon.

D-2. **BASIS.** Allocation of maintenance operations is made on the basis of time, tools, and skills normally available to the various echelons in a combat situation and influenced by maintenance policy and sound maintenance practices, as outlined in AR 750-1.

D-3. **EXPLANATION AND DEFINITIONS.** The maintenance allocation chart designates overall responsibility for the maintenance function on an end item or assembly. Repair and/or rebuild of major assemblies is designated by authority of the Army commander representative, except for the specific subfunctions listed in the maintenance allocation chart. Deviation from maintenance operations allocated in the maintenance allocation chart is authorized only upon approval of the Army commander representative. Maintenance functions will be limited to and defined as follows:

a. **Inspect.** To determine the serviceability of an item by comparing its physical, mechanical, and/or electrical characteristics with established standards through examination.

b. **Test.** To verify serviceability and to detect incipient failure by measuring the mechanical or electrical characteristics of an item and comparing those characteristics with prescribed standards.

c. **Service.** Operations required periodically to keep an item in proper operating condition, i.e., to clean, preserve, drain, paint, or to replenish fuel/lubricants/hydraulic fluids, or compressed air supplies.

d. **Adjust.** Maintain within prescribed limits by bringing into proper or exact position, or by setting the operating characteristics to the specific parameters.

e. **Aline.** To adjust specified variable elements of an item to bring about optimum or desired performance.

f. **Calibrate.** To determine and cause corrections to be made or to be adjusted on instruments or test measuring and diagnostic equipment used in precision measurement. Consists of comparisons of two instruments, one of which is a certified standard of known accuracy, to detect and adjust any discrepancy in the accuracy of the instrument being compared.

TM 9-4910-663-12

g. Install. The act of emplacing, seating, or fixing into position of an item, part, module (component or assembly) in a manner to allow the proper functioning of the equipment/system.

h. Replace. The act of substituting a serviceable like-part, subassembly, module (component or assembly) in a manner to allow the proper functioning of an equipment/system.

i. Repair. The application of maintenance services (inspect, test, service, adjust, align, replace) or other maintenance actions (welding, grinding, riveting, straightening, facing, remachining, or resurfacing) to restore serviceability to an item by correcting specific damage, fault, malfunction, or failure in a part, subassembly, module/component/assembly, end item, or system.

j. Overhaul. That maintenance effort (service/action) necessary to restore an item to a completely serviceable/operational condition as prescribed by maintenance standards (e.g. , DMWR) in pertinent technical publications. Overhaul is normally the highest degree of maintenance performed by the Army. Overhaul does not normally return an item to like new condition.

k. Rebuild. Consists of those services/actions necessary for the restoration of unserviceable equipment to a like-new condition in accordance with original manufacturing standards. Rebuild is the highest degree of material maintenance applied to Army Equipment. The rebuild operation includes the act of returning to zero those age measurements (hours, miles, etc.) considered in classifying Army equipment/components.

l. Symbols. The uppercase letter placed in the appropriate column indicates the lowest level at which that particular function is to be performed.

D-4. EXPLANATION OF FORMAT. The maintenance allocation chart consists of five columns. Each of the columns is explained below:

a. Column 1, Group Number. Column 1 lists group numbers, the purpose of which is to match components, assemblies, subassemblies, and modules with the next higher assembly.

b. Column 2, Component/Assembly. Column 2 lists the next higher group and the item names of components, assemblies, subassemblies, and modules within the group for which maintenance is authorized.

c. Column 3, Maintenance Functions. Column 3 lists the eleven maintenance functions.

d. Column 4, Maintenance Level. The following symbols shall be used to function responsibility:

D-2

| <u>Code</u> | <u>Explanation</u> |
|-------------|-----------------------------|
| C | Operator/crew |
| O | Organizational maintenance |
| F | Direct support maintenance |
| H | General support maintenance |
| D | Depot maintenance |

e. Work Measurement Time. The active repair time required to perform the maintenance function shall be included directly below the symbol identifying the category of maintenance.

f. Column 5, Tools, and Equipment and Remarks. This column shall be used to specify, by code, those tools and test equipment required to perform the designated function.

NOTE

Columns not utilized in this maintenance allocation chart are considered not applicable to this equipment.

Section II. MAINTENANCE ALLOCATION CHART

Table D-1.

| 1 GROUP NUMBER | 2 COMPONENT/ASSEMBLY | 3 MAINTENANCE FUNCTION | 4 MAINTENANCE LEVEL | | | | | 5 TOOLS & EQUIPMENT REMARKS |
|----------------------|-----------------------------|---|------------------------|-------------------|-------------------|-----|------|--------------------------------------|
| | | | C | O | F | H | D | |
| 00 | TEST STAND | INSPECT REPLACE REPAIR | 0.5 | 1.7 | 1.2 0.5 6.5 | | 12.0 | |
| 01 | PANEL ASSY BINDING POST | INSPECT REPLACE REPAIR | | | 0.3 0.4 1.0 | | | |
| 02 | RECTIFIER CHAMBER ASSY | INSPECT REPLACE REPAIR | | | 0.1 0.5 0.4 | | | |
| 03 | BATTERY COMPARTMENT ASSY | INSPECT REPLACE REPAIR | 0.1 | 0.1 | 0.3 1.2 0.3 | | | |
| 04 | INSTRUMENT PANEL ASSY | INSPECT TEST SERVICE ADJUST REPLACE REPAIR | 0.2 0.5 0.1 | 0.2 0.1 0.3 | 0.5 0.5 1.0 | 0.5 | | |

Table D-1 - Continued

| 1 GROUP NUMBER | 2 COMPONENT/ASSEMBLY | 3 MAINTENANCE LEVEL | 4 MAINTENANCE LEVEL | | | | | 5 TOOLS & EQUIPMENT REMARKS |
|----------------------|-----------------------------------|---|------------------------|-------------------|--------------------------|-------------------|---|--------------------------------------|
| | | | C | O | F | H | D | |
| 0401 | PC BOARD ASSY | TEST REPLACE REPAIR | | | 1.5 | 0.6 1.5 1.5 | | |
| 05 | CONTROL PANEL ASSY | INSPECT TEST SERVICE ADJUST REPLACE REPAIR | 0.4 | 0.4 | 0.5 | | | |
| 06 | RHEOSTAT ASSY | REPLACE REPAIR | | | 1.1 1.5 | | | |
| 07 | LINK BOARD ASSY | REPLACE ADJUST REPAIR | | 0.3 | 0.8 0.5 | | | |
| 08 | PANEL DRIVE CON- TROL ASSY | TEST REPLACE REPAIR | | | 0.2 0.7 1.0 | | | |
| 09 | LOAD BANK ASSY | REPLACE REPAIR | | | 3.8 2.5 | | | |
| 0901 | LOAD BANK | TEST REPLACE REPAIR | | | 0.5 2.3 2.5 | | | |
| 10 | PANEL ASSY RESISTOR AND SHUNT | INSPECT TEST REPLACE REPAIR | | | 0.2 0.2 0.9 1.0 | | | |
| 11 | DIODE ASSY | TEST REPLACE REPAIR | | | 0.4 0.7 1.0 | | | |
| 12 | VARIDRIVE ASSY | INSPECT REPLACE SERVICE REPAIR | | 0.3 0.4 | 2.0 2.0 | 7.0 12.0 | | |
| | LUBRICATION HOSES AND FITTINGS | INSPECT SERVICE REPLACE | | 0.3 0.4 0.5 | | | | |
| 13 | DRIVE BRACKET ASSY | REPLACE REPAIR | | | 0.4 0.5 | | | |

Table D-1 - Continued

| 1 GROUP NUMBER | 2 COMPONENT/ASSEMBLY | 3 MAINTENANCE LEVEL | 4 MAINTENANCE C O F | | | LEVEL H | 5 TOOLS & EQUIPMENT REMARKS |
|----------------------|-------------------------|---------------------------|---------------------------|--|--|-------------------|--------------------------------------|
| 14 | STARTER | TEST REPLACE REPAIR | 0.3 | | | 0.6 1.1 1.0 | |
| 15 | BLOWER ASSY | REPLACE REPAIR | | | | 2.5 2.0 | |
| 16 | ACCESSORIES | INSPECT REPLACE | 0.3 | | | | |
| | | | 0.5 | | | | |

APPENDIX E

EXPENDABLE SUPPLIES AND MATERIALS LIST

Not applicable.

INDEX

| Subject | Paragraph, Figure, Table Number |
|--|--|
| A | |
| AC/DC Systems (Externally Rectified), Test | |
| Connections | F 2-13 |
| Accessories | F 2-7 |
| Administrative Storage | 1-3 |
| Alternators, Test Connections | F 2-23, F 2-24, F 2-25, F 2-26 |
| B | |
| Battery Connection | F 2-8 |
| C | |
| Calibration of Test Stand | 4-4 |
| Checkout of Test Stand | 4-3 |
| Cleaning | 2-12 |
| Connections, Power-Terminal Board Voltage Conversion . . . | F 4-2 |
| Consumable Supplies and Materials | 3-1 |
| Control Panel Assembly, Organizational Maintenance | T 3-1 4-9 |
| D | |
| Data Plates | 1-8 F 1-1, F 1-2, F 1-3 |
| DC Generators Without Regulators, Testing | F 2-16, F 2-17, F 2-18 |
| Description of Test Stand | 1-7 |
| Destruction to Prevent Enemy Use | 1-4 |
| F | |
| Forms and Records, Maintenance | 1-2 |
| G | |
| Generator-Regulators | F 2-12, F 2-16, F 2-17, F 2-18, F 2-20, F 2-21, F 2-22 |

INDEX - Continued

| Subject | Paragraph, Figure, Table Number |
|--|---------------------------------------|
| I | |
| Initial Control Positions | T 2-1 |
| Installation of Test Stand | 4-2 |
| Instrument Panel Assembly, Organizational Maintenance . . | 4-8 |
| Instruments and Controls | 2-2 |
| | F 2-1, |
| | F 2-2, |
| | F 2-3, |
| | F 2-4, |
| | F 2-5, |
| Internal Ground Field and External Ground Field Generators, Testing | 2-7 |
| L | |
| Lubrication Chart | 3-2 |
| | F 3-1 |
| Lubrication Instructions, General | 3-3 |
| Lubrication, Organizational Maintenance | 4-5 |
| Lubrication Under Unusual Conditions | 3-4 |
| M | |
| Maintenance, Organizational Maintenance Level | 4-7 |
| Major Assemblies of Test Stand | F 4-3 |
| | F 4-4 |
| Mechanical Actuation of Lever Operated Starter Start Switch | F 2-11 |
| Mounting Direct Driven Generator/Alternators | F 2-9 |
| Mounting Pulley Driven Generator/Alternators | F 2-10 |
| Mounting of Components Being Tested | 2-4 |
| N, O | |
| Operation and Test Instructions | 2-9 |
| Operation in Extreme Cold Weather Conditions | 2-13 |
| Operation in Extreme Hot Weather Conditions | 2-14 |
| Operation in High Humidity | 2-15 |
| Operation of Test Stand, General | 2-5 |
| Operator Maintenance | 3-7 |
| Operator PMCS Procedures | 2-11 |
| | T 2-2 |
| Operator Troubleshooting Table | 3-6 |
| | T 3-2 |

INDEX - Continued

| Subject | Paragraph, Figure, Table Number |
|---|---------------------------------------|
| N,O--continued | |
| Organizational Maintenance | |
| Control Panel Assembly | 4-9 |
| Instrument Panel Assembly | 4-8 |
| Lubrication | 4-5 |
| PMCS | 4-6 |
| Varidrive Assembly | 4-10 |
| Outline Dimensions, Test Stand | F 4-1 |
| P | |
| PMCS Procedures, Operator | 2-11 |
| | T 2-2 |
| Power Requirements Chart | T 4-1 |
| Preparation for Operation | 2-3 |
| Q | |
| Quality Assurance/Quality Control | 1-5 |
| Quality Deficiency Report | 1-6 |
| R | |
| Regulator Mounting Bracket Components | F 2-6 |
| S | |
| Scope of Manual | 1-1 |
| Specific Operating Modes | 2-6 |
| Starters, Test Connections | F 2-29 |
| T | |
| Tabulated Data | 1-9 |
| Test Connections | |
| AC/DC Systems (Externally Rectified) | F 2-13 |
| Alternators | F 2-23, |
| | F 2-24, |
| | F 2-25, |
| | F 2-26 |
| Generator-Regulators | F 2-12, |
| | F 2-16, |
| | F 2-17, |
| | F 2-18, |
| | F 2-20 |
| | F 2-21, |
| | F 2-22 |

INDEX - Continued

| Subject | Paragraph, Figure, Table Number |
|--|---------------------------------------|
| T--Continued | |
| Starters | F 2-27, F 2-28, F 2-29 |
| Testing | |
| DC Generators Without Regulators | F 2-16, F 2-17, F 2-18 |
| Internal Ground Field or External Ground Field Generators | 2-7 |
| Voltage Regulators | 2-8 |
| U | |
| Unpacking and Inspection of Test Stand | 4-1 |
| V | |
| Varidrive Assembly, Organizational Maintenance | 4-10 |
| Voltage Conversion, Power Terminal Board Connections . . . | F 4-2 |
| Voltage Regulators, Testing | 2-8 |
| W, X, Y, Z | |

TM 9-4910-663-12

By Order of the Secretary of the Army:

Official:

E. C. MEYER
General, United States Army
Chief of Staff

J. C. PENNINGTON
Major General, United States Army
The Adjutant General

Distribution:

To be distributed in accordance with DA Form 12-25A, Operator maintenance requirements for Shop Equipment, Miscellaneous.

RECOMMENDED CHANGES TO EQUIPMENT TECHNICAL PUBLICATIONS

SOMETHING WRONG WITH THIS PUBLICATION?



THEN... JOT DOWN THE DOPE ABOUT IT ON THIS FORM. CAREFULLY TEAR IT OUT. FOLD IT AND DROP IT IN THE MAIL!

FROM: (PRINT YOUR UNIT'S COMPLETE ADDRESS)

Your mailing address

DATE SENT

Date you mail in form

PUBLICATION NUMBER

TM 9-4910-663-12

PUBLICATION DATE

10 June 1981

PUBLICATION TITLE Operator & Organiza-

tional Maintenance Manual on Test

Stand. Automotive Generator, Alter-

nator, etc.

BE EXACT . PIN-POINT WHERE IT IS

| PAGE NO | PARA-GRAPH | FIGURE NO | TABLE NO |
|---------|------------|-----------|----------|
| p1-4 | | | |
| p2-13 | 2-7 | | |

IN THIS SPACE TELL WHAT IS WRONG AND WHAT SHOULD BE DONE ABOUT IT:

#9 - Change "Varadrive to "Varidrive".

Line 7 - Change "10-30" to "0-30"

SAMPLE

PRINTED NAME, GRADE OR TITLE AND TELEPHONE NUMBER

JOHN DOE SP/4 XXX-XXXX

SIGN HERE

John Doe

DA FORM 2028-2
1 JUL 79

PREVIOUS EDITIONS ARE OBSOLETE.

P.S. --IF YOUR OUTFIT WANTS TO KNOW ABOUT YOUR RECOMMENDATION MAKE A CARBON COPY OF THIS AND GIVE IT TO YOUR HEADQUARTERS

RECOMMENDED CHANGES TO EQUIPMENT TECHNICAL PUBLICATIONS



THEN...JOT DOWN THE
DOPE ABOUT IT ON THIS FORM.
CAREFULLY TEAR IT OUT, FOLD IT
AND DROP IT IN THE MAIL.

SOMETHING WRONG WITH PUBLICATION

FROM: (PRINT YOUR UNIT'S COMPLETE ADDRESS)

DATE SENT

PUBLICATION NUMBER

PUBLICATION DATE

PUBLICATION TITLE

BE EXACT PIN-POINT WHERE IT IS

PAGE
NO.

PARA-
GRAPH

FIGURE
NO.

TABLE
NO.

IN THIS SPACE, TELL WHAT IS WRONG
AND WHAT SHOULD BE DONE ABOUT IT.

TEAR ALONG PERFORATED LINE

PRINTED NAME, GRADE OR TITLE AND TELEPHONE NUMBER

SIGN HERE

FILL IN YOUR
UNITS ADDRESS



DEPARTMENT OF THE ARMY

OFFICIAL BUSINESS



NO POSTAGE
NECESSARY
IF MAILED
IN THE
UNITED STATES

BUSINESS REPLY MAIL

FIRST CLASS

PERMIT NO. 82

ROCK ISLAND IL

POSTAGE WILL BE PAID BY ROCK ISLAND ARSENAL



Director
Armament and Chemical Acquisition
and Logistics Activity
ATTN: AMSTA-AC-NML
Rock Island, IL 61201-9948



TEAR ALONG PERFORATED LINE

The Metric System and Equivalents

Linear Measure

1 centimeter = 10 millimeters = .39 inch
 1 decimeter = 10 centimeters = 3.94 inches
 1 meter = 10 decimeters = 39.37 inches
 1 dekameter = 10 meters = 32.8 feet
 1 hectometer = 10 dekameters = 328.08 feet
 1 kilometer = 10 hectometers = 3,280.8 feet

Weights

1 centigram = 10 milligrams = .15 grain
 1 decigram = 10 centigrams = 1.54 grains
 1 gram = 10 decigrams = .035 ounce
 1 dekagram = 10 grams = .35 ounce
 1 hectogram = 10 dekagrams = 3.52 ounces
 1 kilogram = 10 hectograms = 2.2 pounds
 1 quintal = 100 kilograms = 220.46 pounds
 1 metric ton = 10 quintals = 1.1 short tons

Liquid Measure

1 centiliter = 10 milliliters = .34 fl. ounce
 1 deciliter = 10 centiliters = 3.38 fl. ounces
 1 liter = 10 deciliters = 33.81 fl. ounces
 1 dekaliter = 10 liters = 2.64 gallons
 1 hectoliter = 10 dekaliters = 26.42 gallons
 1 kiloliter = 10 hectoliters = 264.18 gallons

Square Measure

1 sq. centimeter = 100 sq. millimeters = .155 sq. inch
 1 sq. decimeter = 100 sq. centimeters = 15.5 sq. inches
 1 sq. meter (centare) = 100 sq. decimeters = 10.76 sq. feet
 1 sq. dekameter (are) = 100 sq. meters = 1,076.4 sq. feet
 1 sq. hectometer (hectare) = 100 sq. dekameters = 2.47 acres
 1 sq. kilometer = 100 sq. hectometers = .386 sq. mile

Cubic Measure

1 cu. centimeter = 1000 cu. millimeters = .06 cu. inch
 1 cu. decimeter = 1000 cu. centimeters = 61.02 cu. inches
 1 cu. meter = 1000 cu. decimeters = 35.31 cu. feet

Approximate Conversion Factors

| To change | To | Multiply by | To change | To | Multiply by |
|---------------|--------------------|-------------|--------------------|---------------|-------------|
| inches | centimeters | 2.540 | ounce-inches | newton-meters | .007062 |
| feet | meters | .305 | centimeters | inches | .394 |
| yards | meters | .914 | meters | feet | 3.280 |
| miles | kilometers | 1.609 | meters | yards | 1.094 |
| square inches | square centimeters | 6.451 | kilometers | miles | .621 |
| square feet | square meters | .093 | square centimeters | square inches | .155 |
| square yards | square meters | .836 | square meters | square feet | 10.764 |
| square miles | square kilometers | 2.590 | square meters | square yards | 1.196 |
| acres | square hectometers | .405 | square kilometers | square miles | .386 |
| cubic feet | cubic meters | .028 | square hectometers | acres | 2.471 |
| cubic yards | cubic meters | .765 | cubic meters | cubic feet | 35.315 |
| fluid ounces | milliliters | 29.573 | cubic meters | cubic yards | 1.308 |
| pints | liters | .473 | milliliters | fluid ounces | .034 |
| quarts | liters | .946 | liters | pints | 2.113 |
| gallons | liters | 3.785 | liters | quarts | 1.057 |
| ounces | grams | 28.349 | liters | gallons | .264 |
| pounds | kilograms | .454 | grams | ounces | .035 |
| short tons | metric tons | .907 | kilograms | pounds | 2.205 |
| pound-feet | newton-meters | 1.356 | metric tons | short tons | 1.102 |
| pound-inches | newton-meters | .11296 | | | |

Temperature (Exact)

°F Fahrenheit temperature 5/9 (after subtracting 32) Celsius temperature °C

PIN: 049159-001